

Guastavino Structural Tile Vaulting in Pittsburgh

Lecture 4 – Structural Innovations in Engineering

OLLI at PITT (2021.04.06)

Matthew Schlueb, Instructor



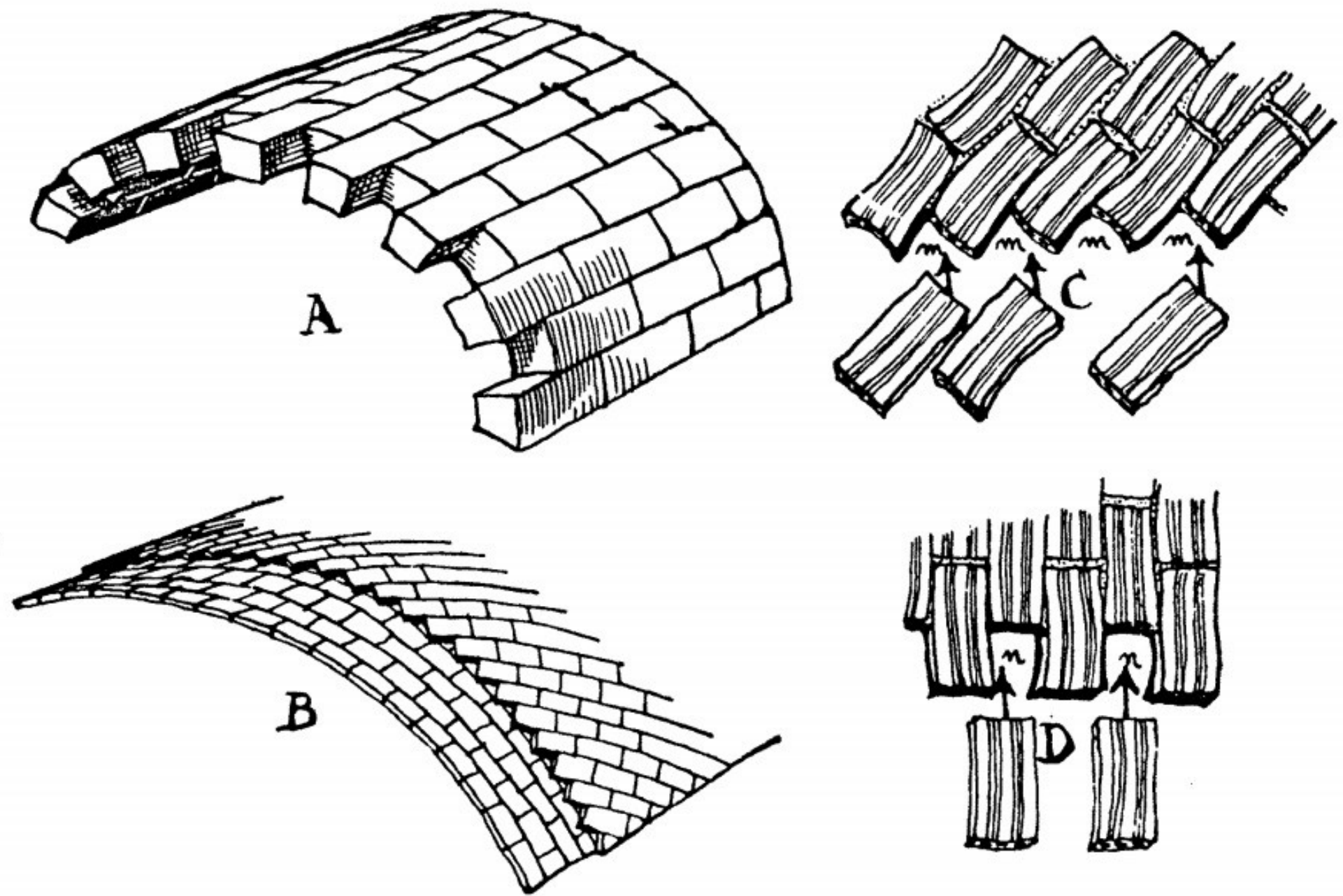


Fig. 1. Stone vs. tile vaults (Moya, *Bóvedas tabicadas*).

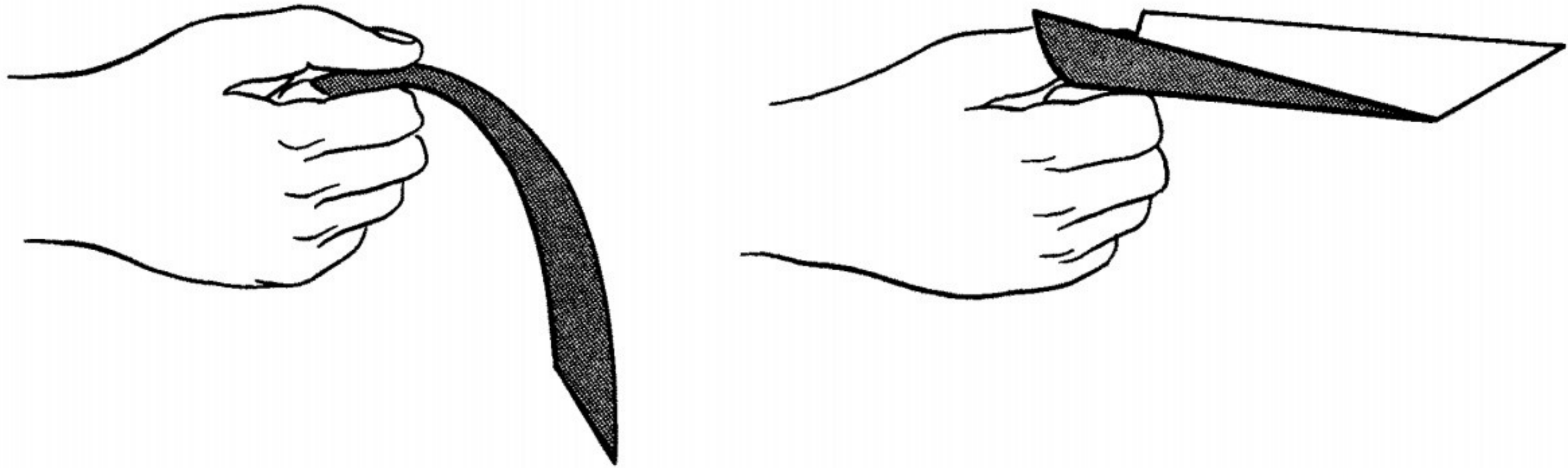
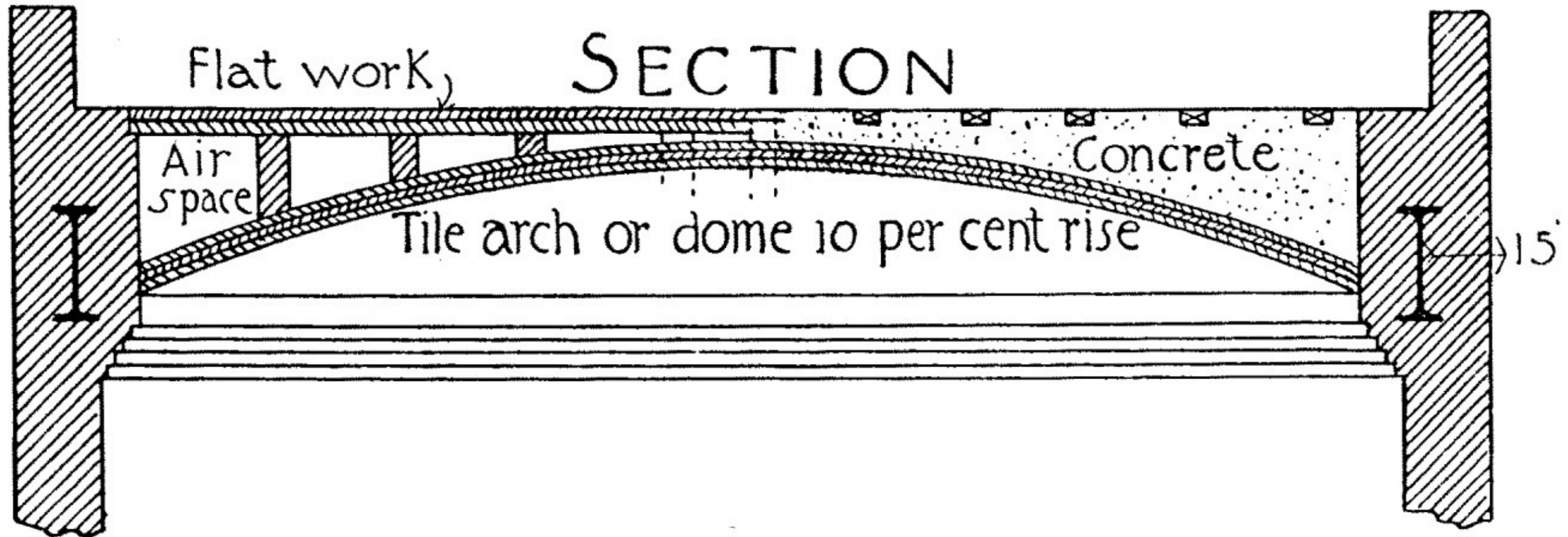


Fig. 2. A surface (paper), unable to support its own weight, can sustain that and more if given a slight curvature (Salvadori & Heller, *Structure in Architecture*, Englewood Cliffs, N. J., 1963).





SECTION

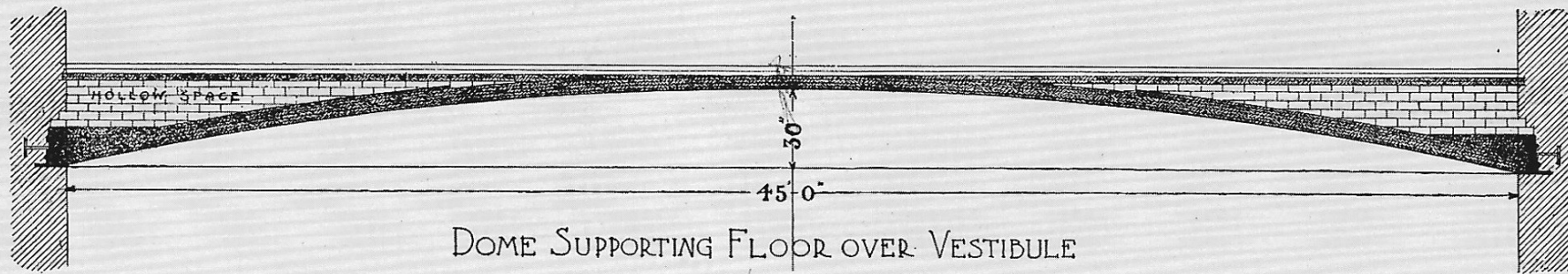
Flat work,

Air space

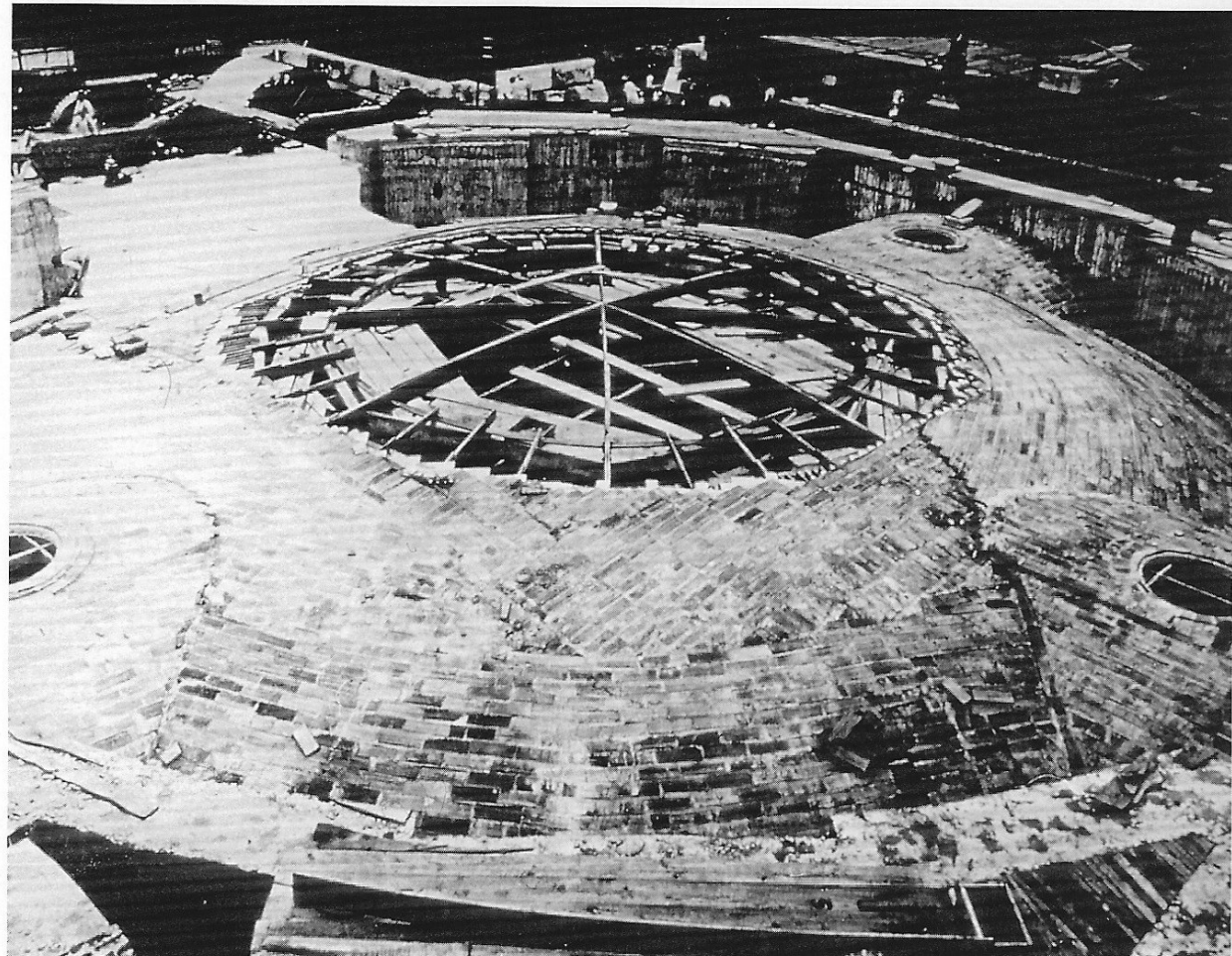
Concrete

Tile arch or dome 10 per cent rise

15'

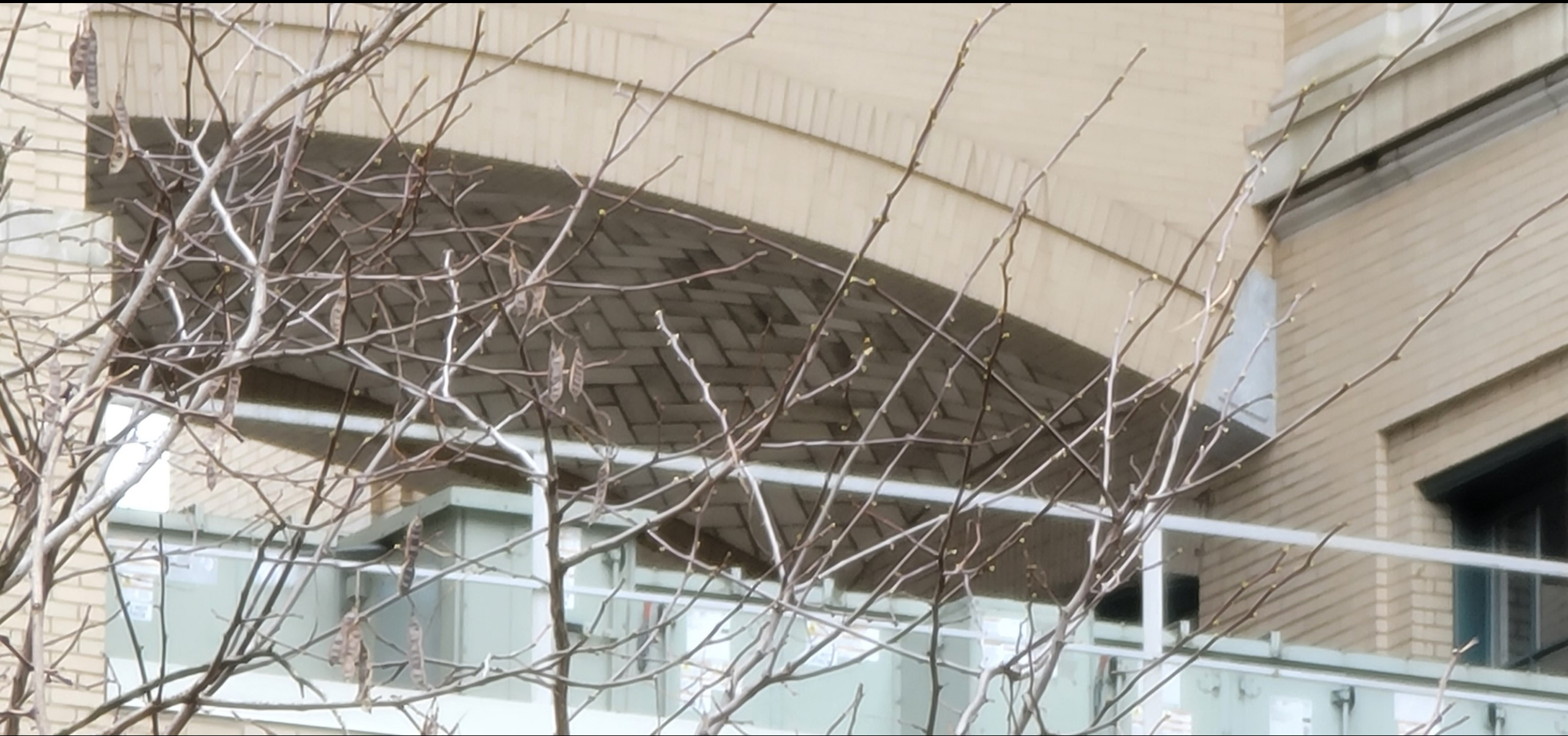


DOME SUPPORTING FLOOR OVER VESTIBULE



















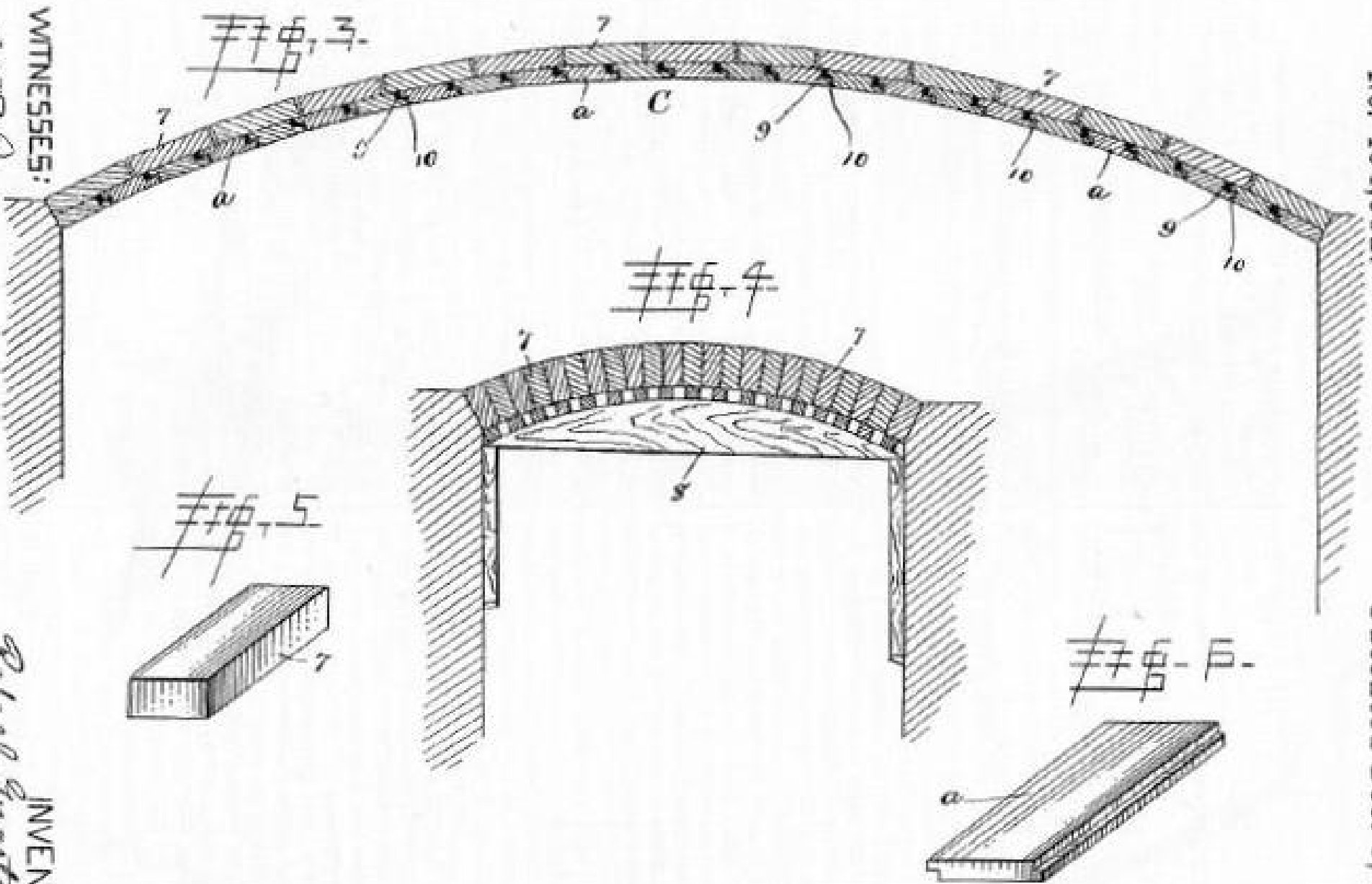
(No Model.)

2 Sheets—Sheet 2.

R. GUASTAVINO.
CONSTRUCTION OF BUILDINGS.

No. 464,562.

Patented Dec. 8, 1891.



WITNESSES:

M. B. Brown,
Ray. Walker,

INVENTOR:

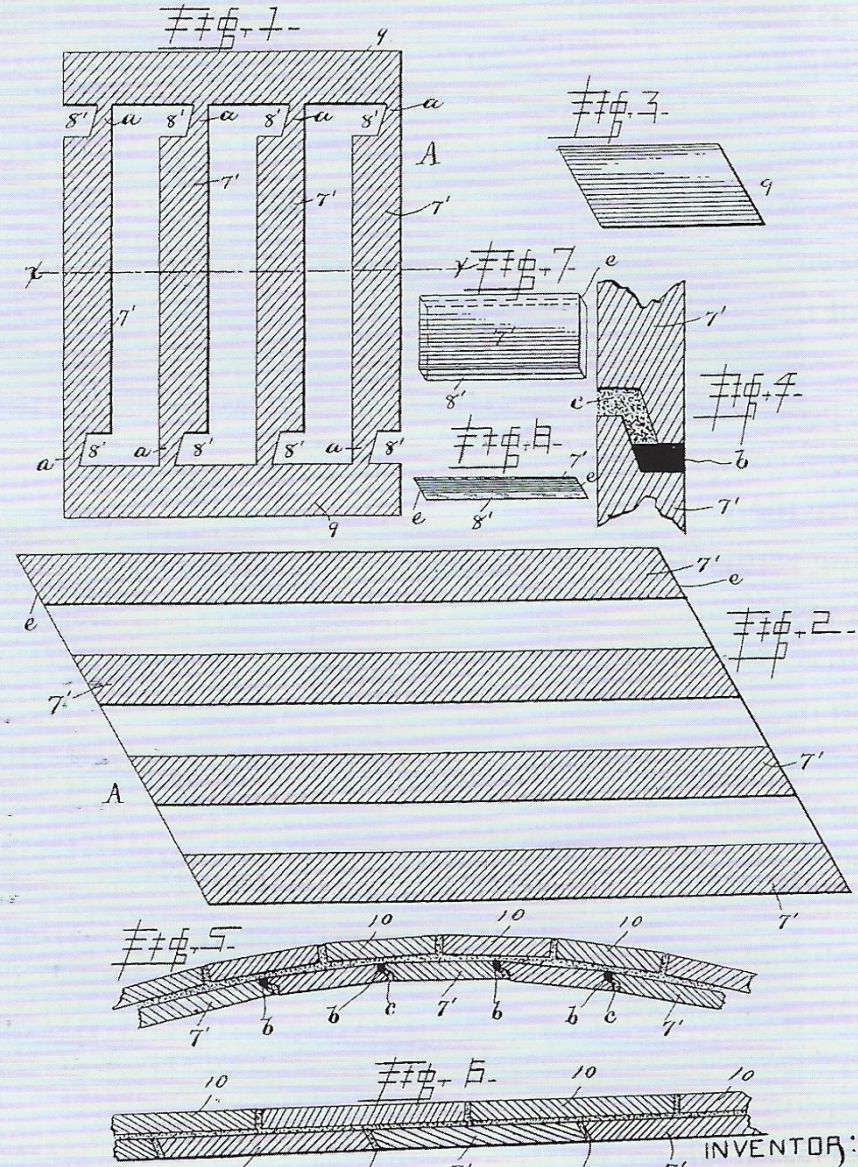
Rafael Guastavino,
by J. M. Brown,
Attorney.

(No Model.)

R. GUASTAVINO.
BUILDING TILE.

No. 548,160.

Patented Oct. 15, 1895.

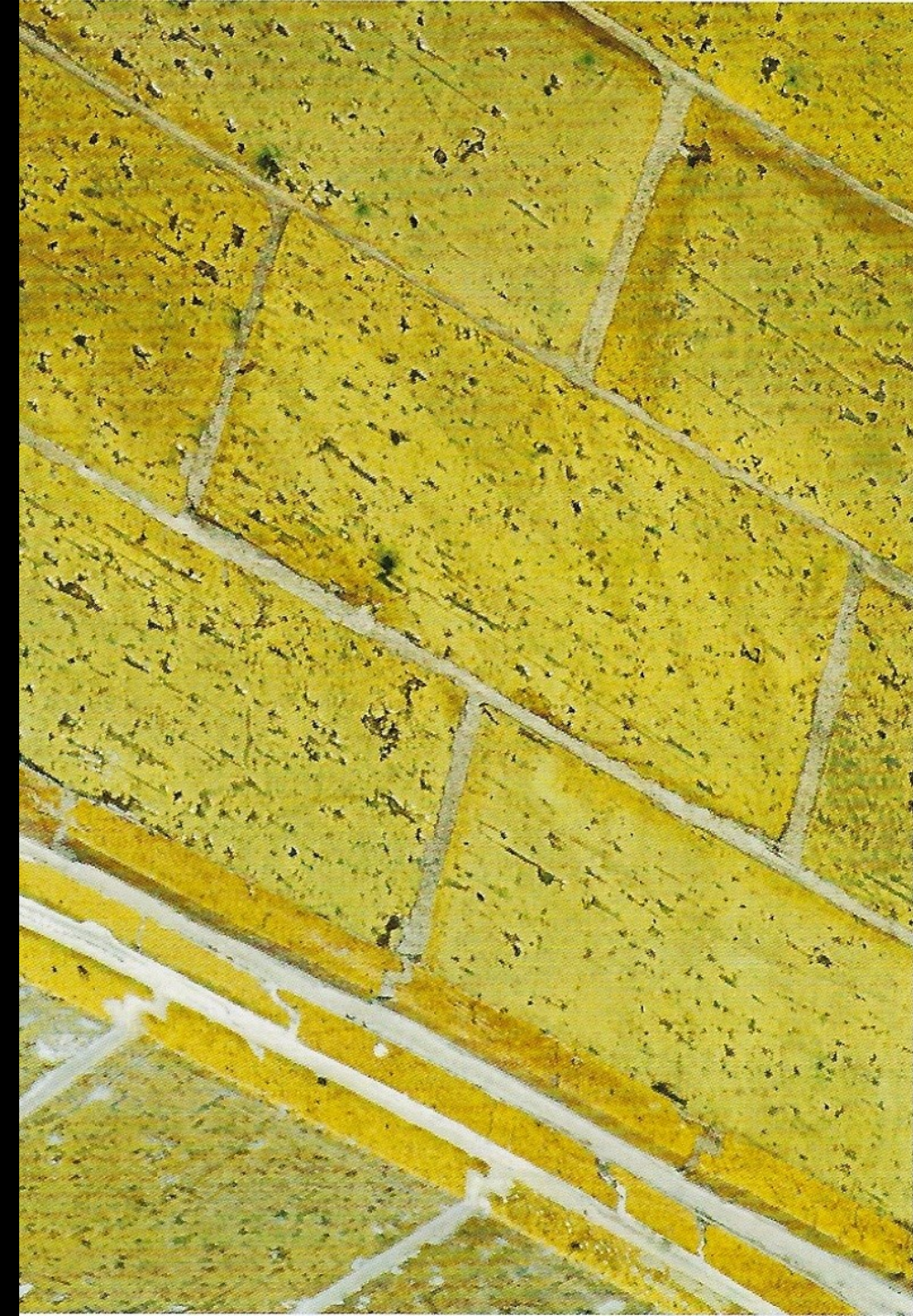


WITNESSES:

W. Bowen
Benj. Miller

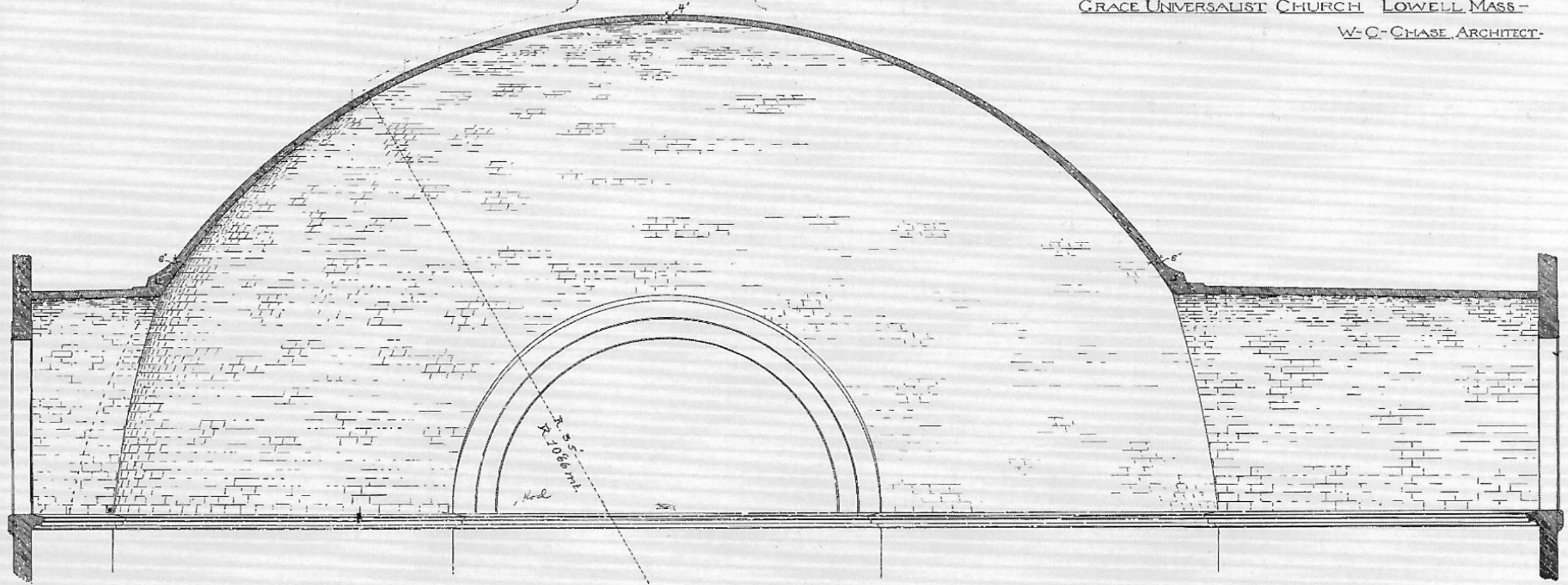
INVENTOR:

Rafael Guastavino
By J. M. Bowen
attorney.



GUASTAVINO FIRE-PROOF CONSTRUCTION

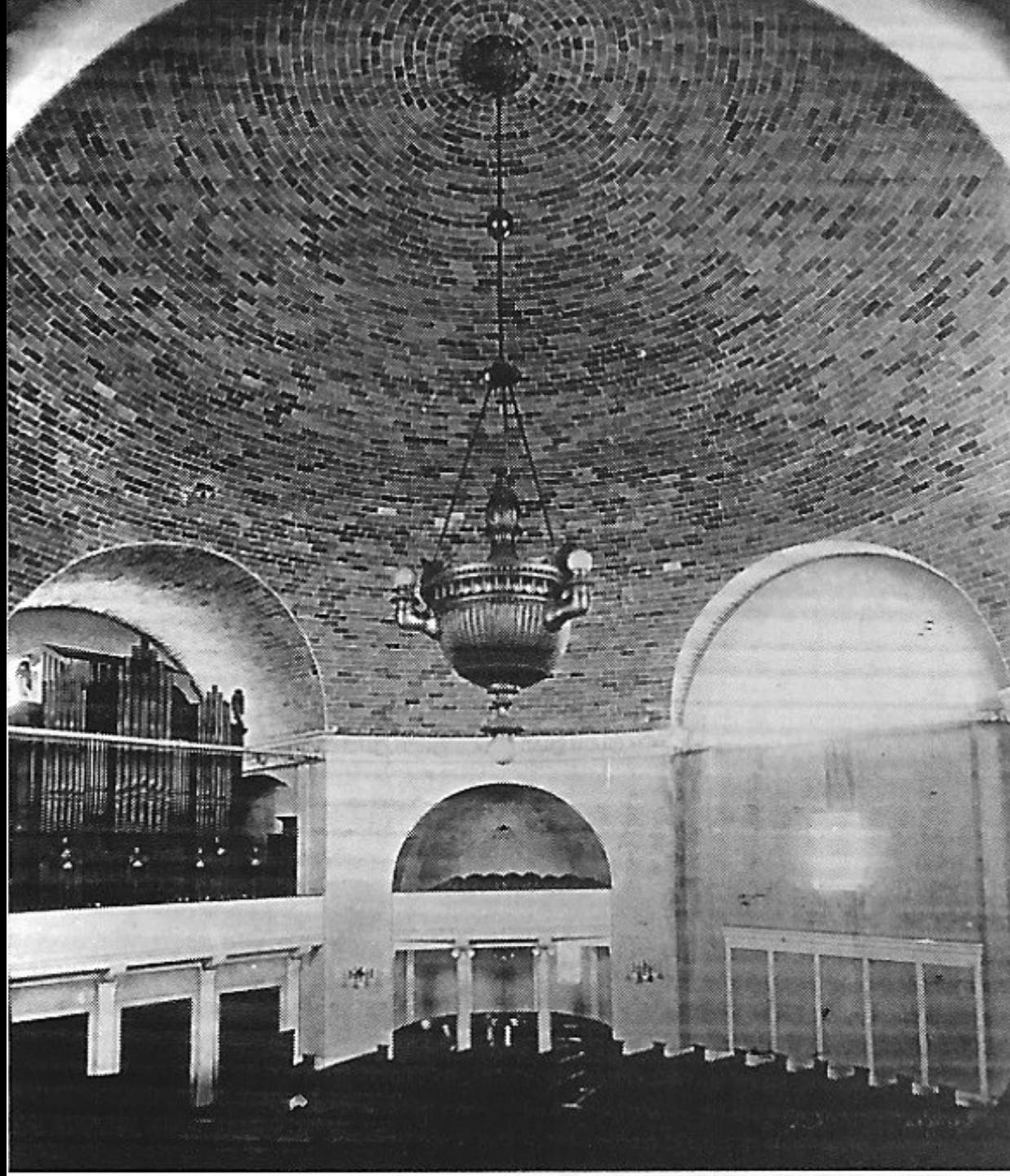
GRACE UNIVERSALIST CHURCH LOWELL MASS -
W. C. CHASE, ARCHITECT.



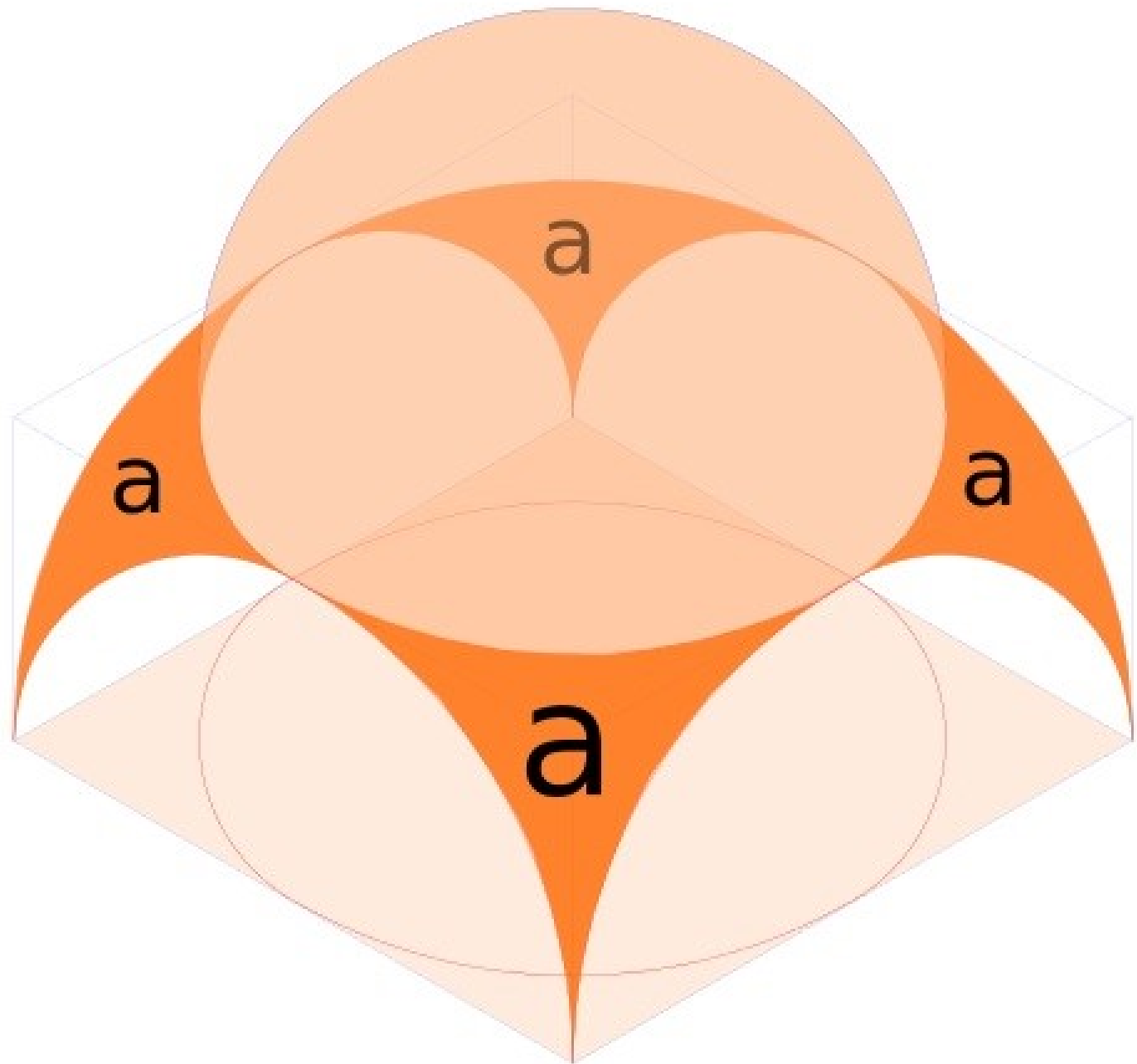
SCALE $\frac{3}{8}$ " = ONE FOOT

SECTION THROUGH DOME SEVENTY FEET IN DIAMETER.

BUILT IN
OCTOBER - NOVEMBER - 1895 -
SUPERINTENDED BY R. GUASTAVINO¹⁸















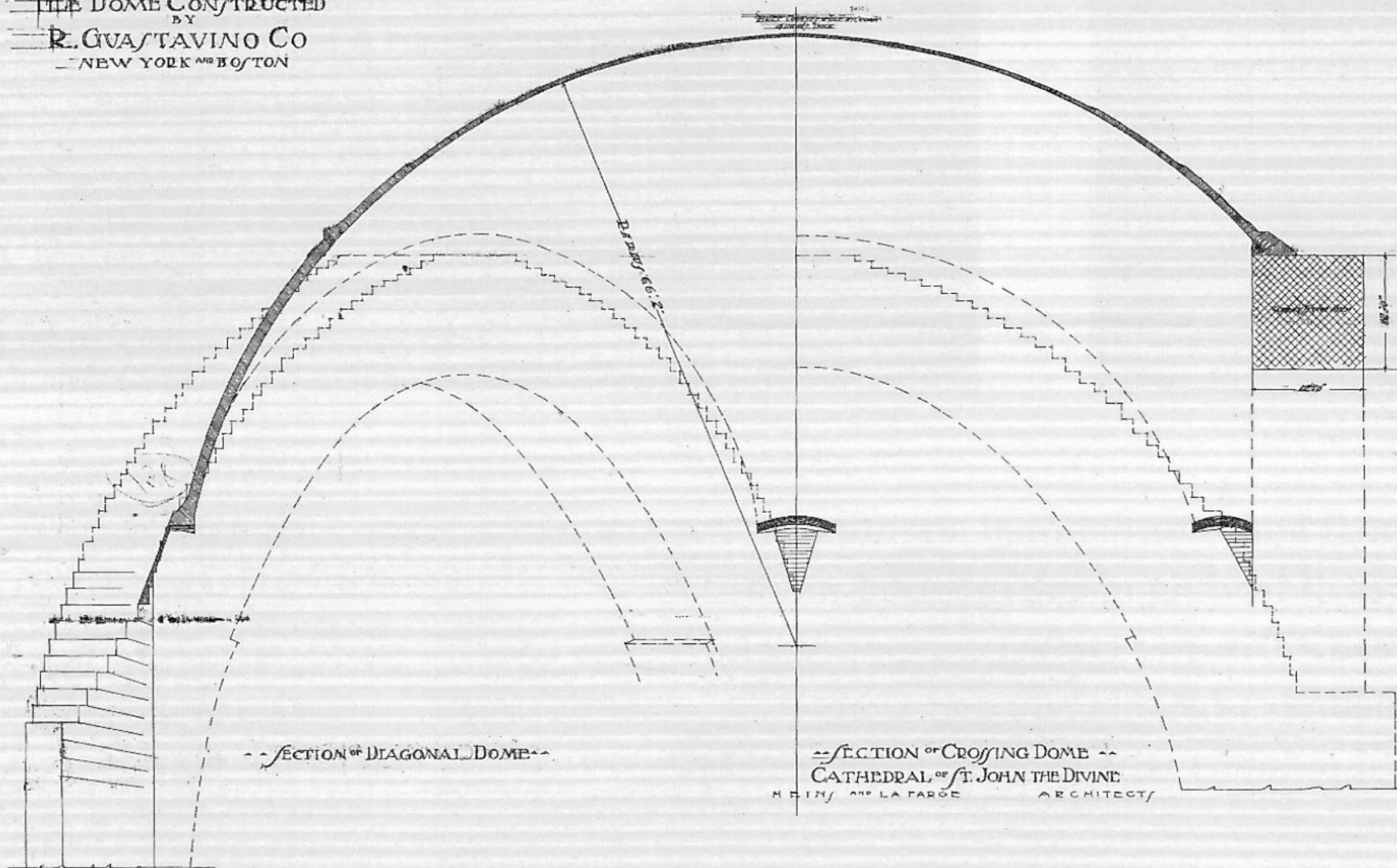






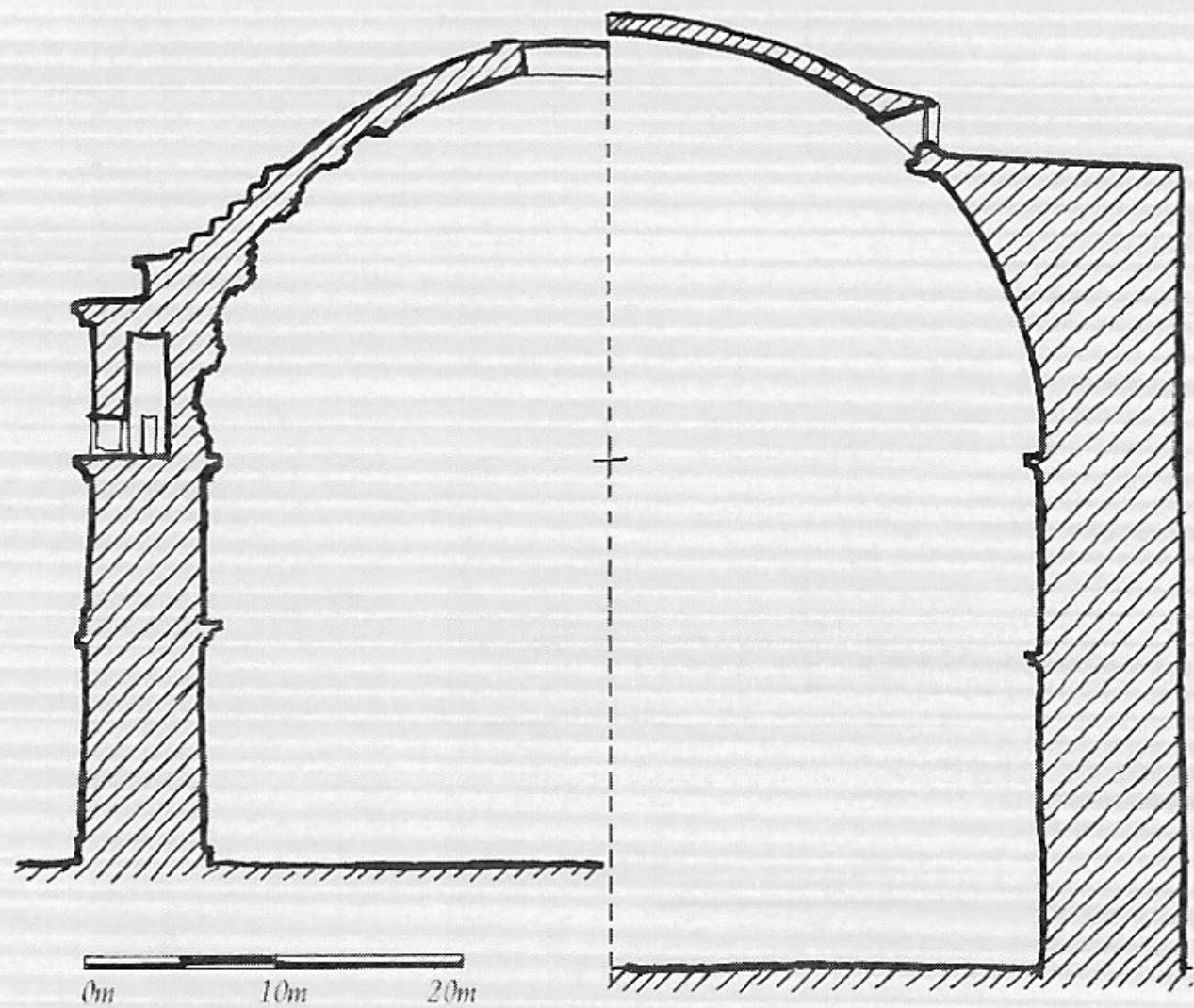
THE DOME CONSTRUCTED
 BY
 R. GVASTAVINO CO
 NEW YORK AND BOSTON

1900
 RICHARD L. LINDSAY ARCHT. & ENGRS.
 120 N. 4TH ST. PHILA.



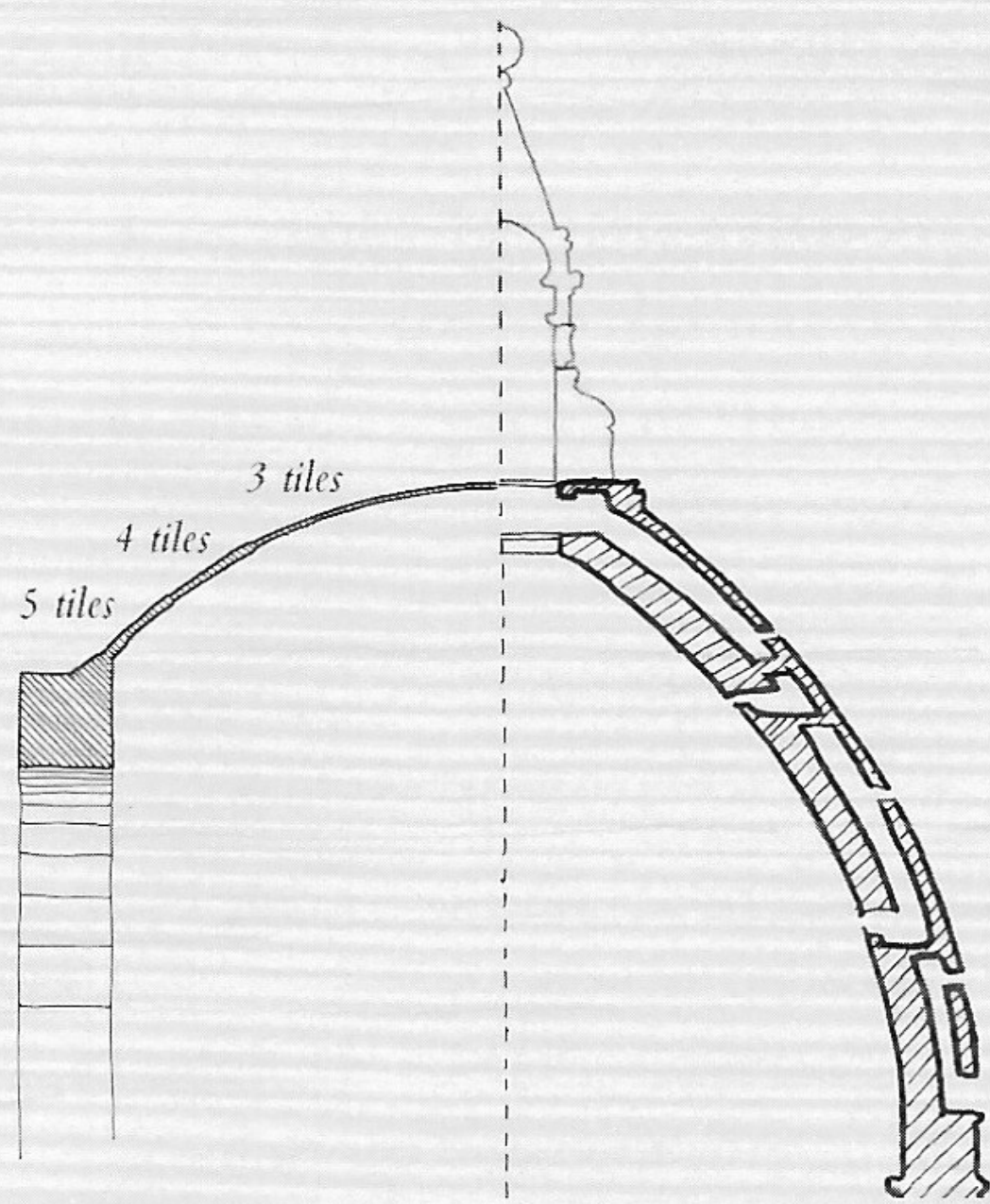
-- SECTION OF DIAGONAL DOME --

-- SECTION OF CROSSING DOME --
 CATHEDRAL OF ST. JOHN THE DIVINE
 HENRY AND LA FARGE ARCHITECTS



Pantheon (Rome)

Hagia Sophia



St. John the Divine

Florence Cathedral

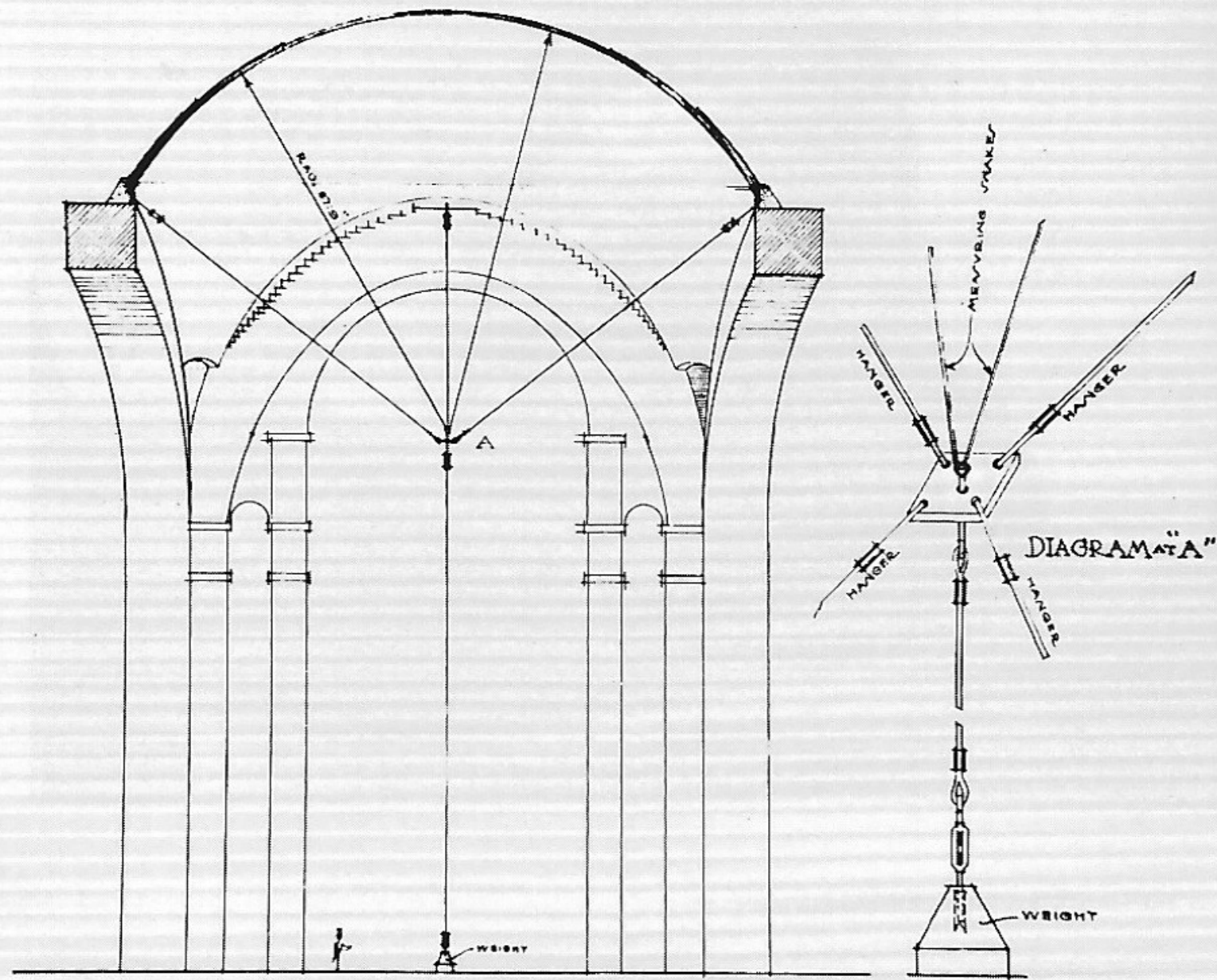
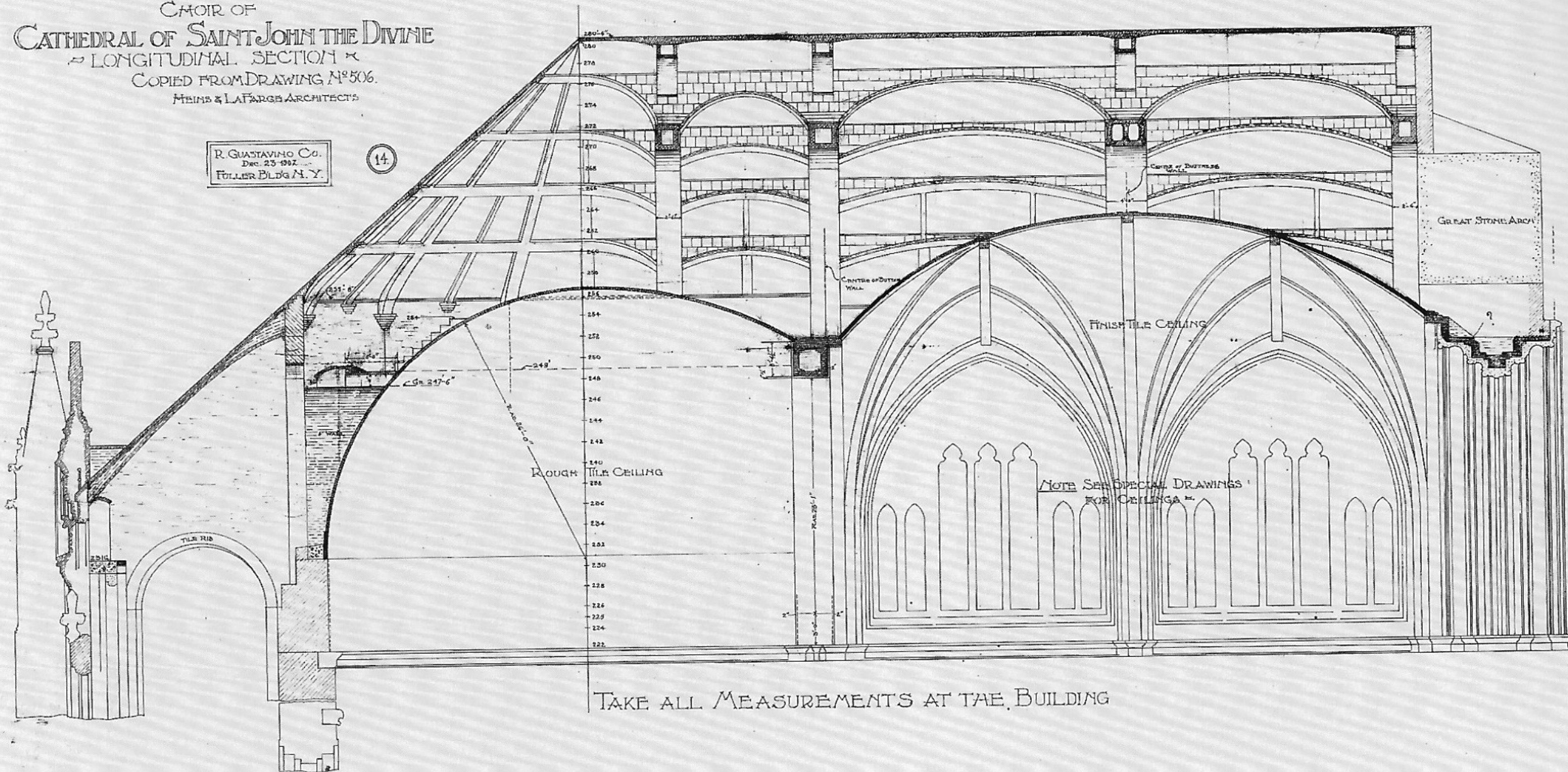


DIAGRAM SHOWING METHOD OF OBTAINING CURVATURE
 OF DOME OVER CROSSING CATHEDRAL OF ST. JOHN'S THE DIVINE

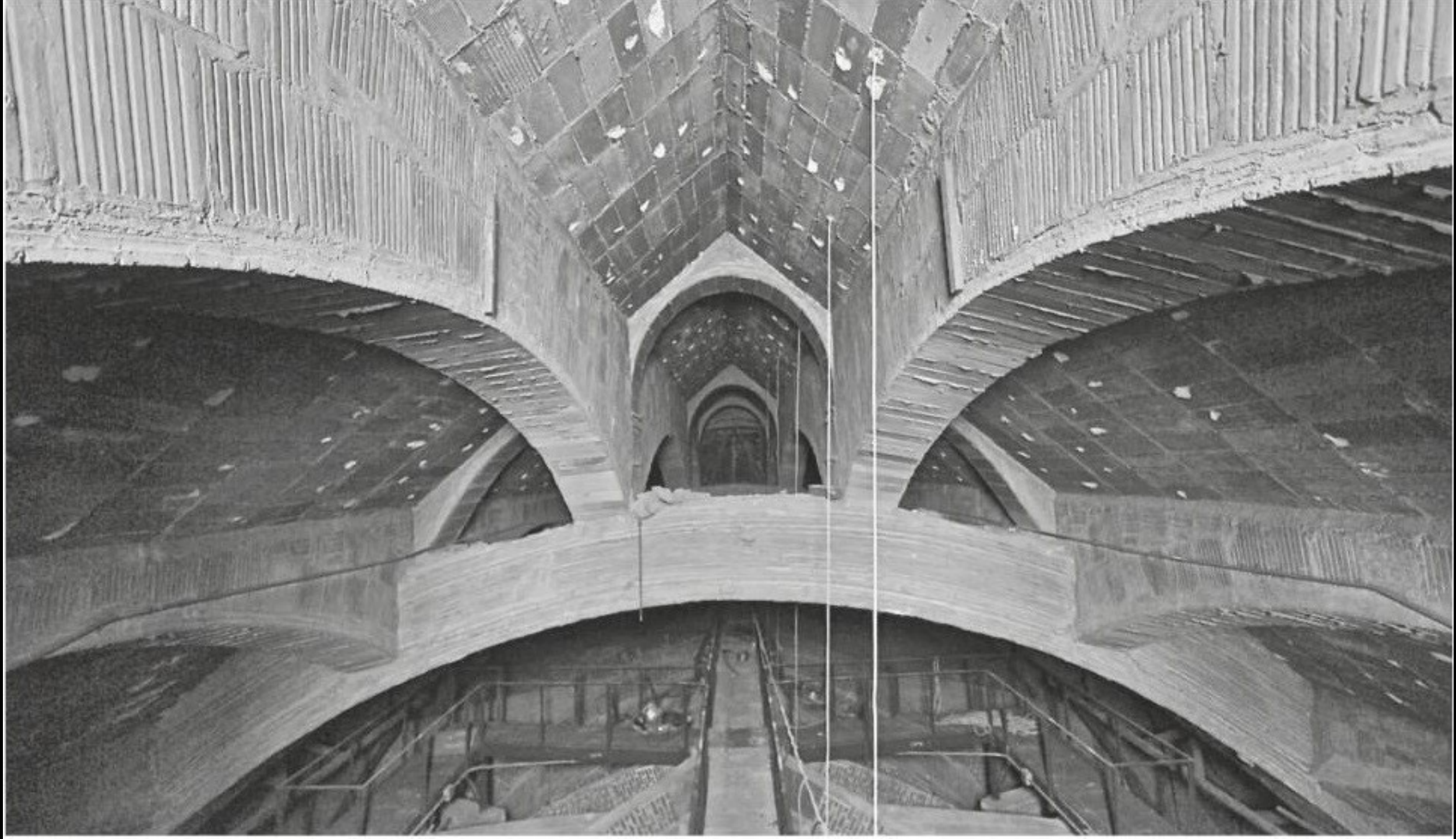
CHOIR OF
 CATHEDRAL OF SAINT JOHN THE DIVINE
 LONGITUDINAL SECTION
 COPIED FROM DRAWING N^o 506.
 HEINS & LAFARGE ARCHITECTS

R. GUASTAVINO CO.
 DEC. 25-1902
 FULLER BLDG N. Y.

14

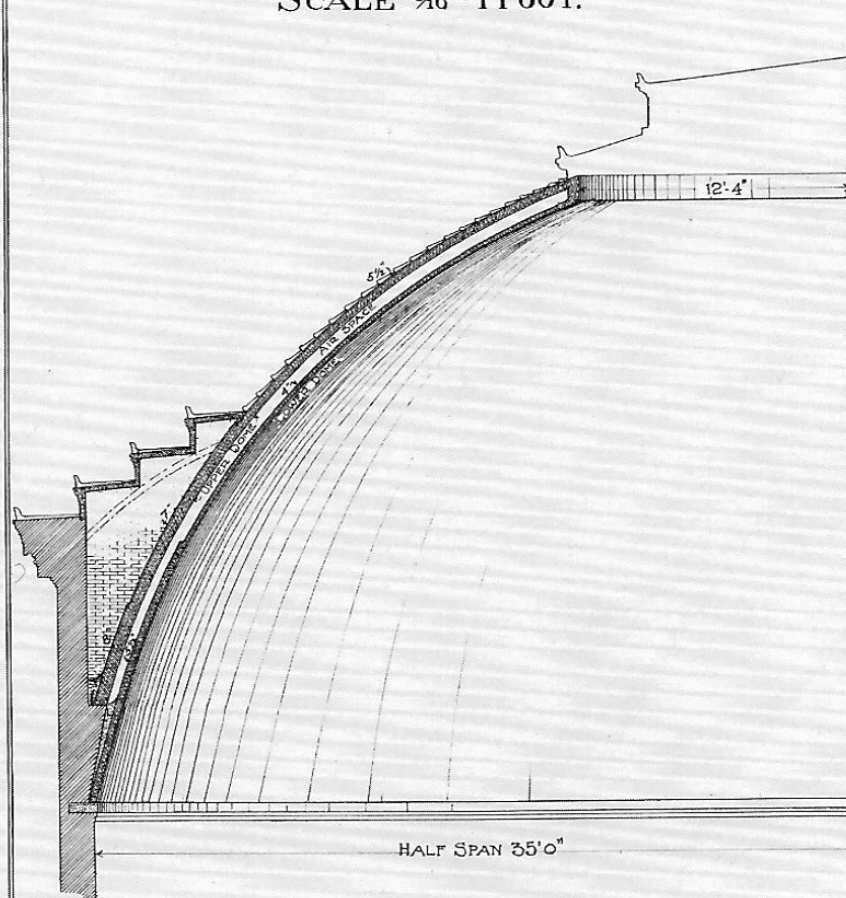


TAKE ALL MEASUREMENTS AT THE BUILDING



GUASTAVINO DOME, SPAN 70 FEET.

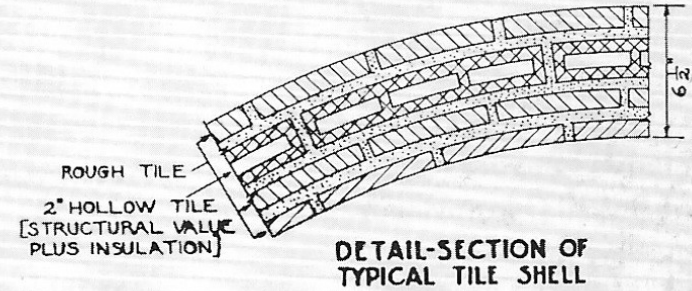
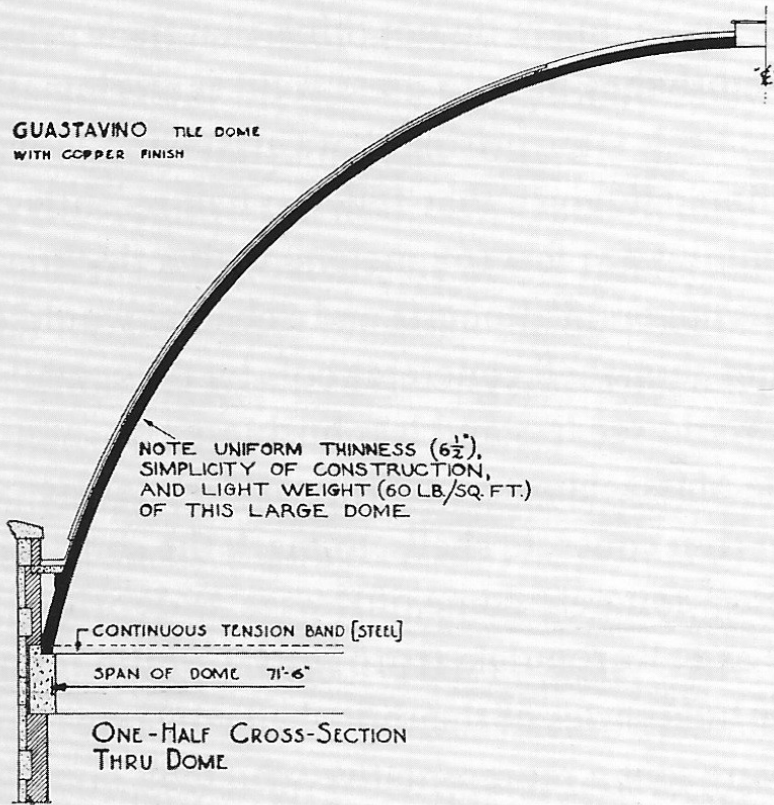
SCALE $\frac{3}{16}'' = 1$ FOOT.



APPROVED IN 1897 FOR LIBRARY UNIVERSITY OF NEW YORK.

R. GUASTAVINO CO.
FUDDER BUILDING
New York City

GUASTAVINO TIMBREL ARCH CONSTRUCTION



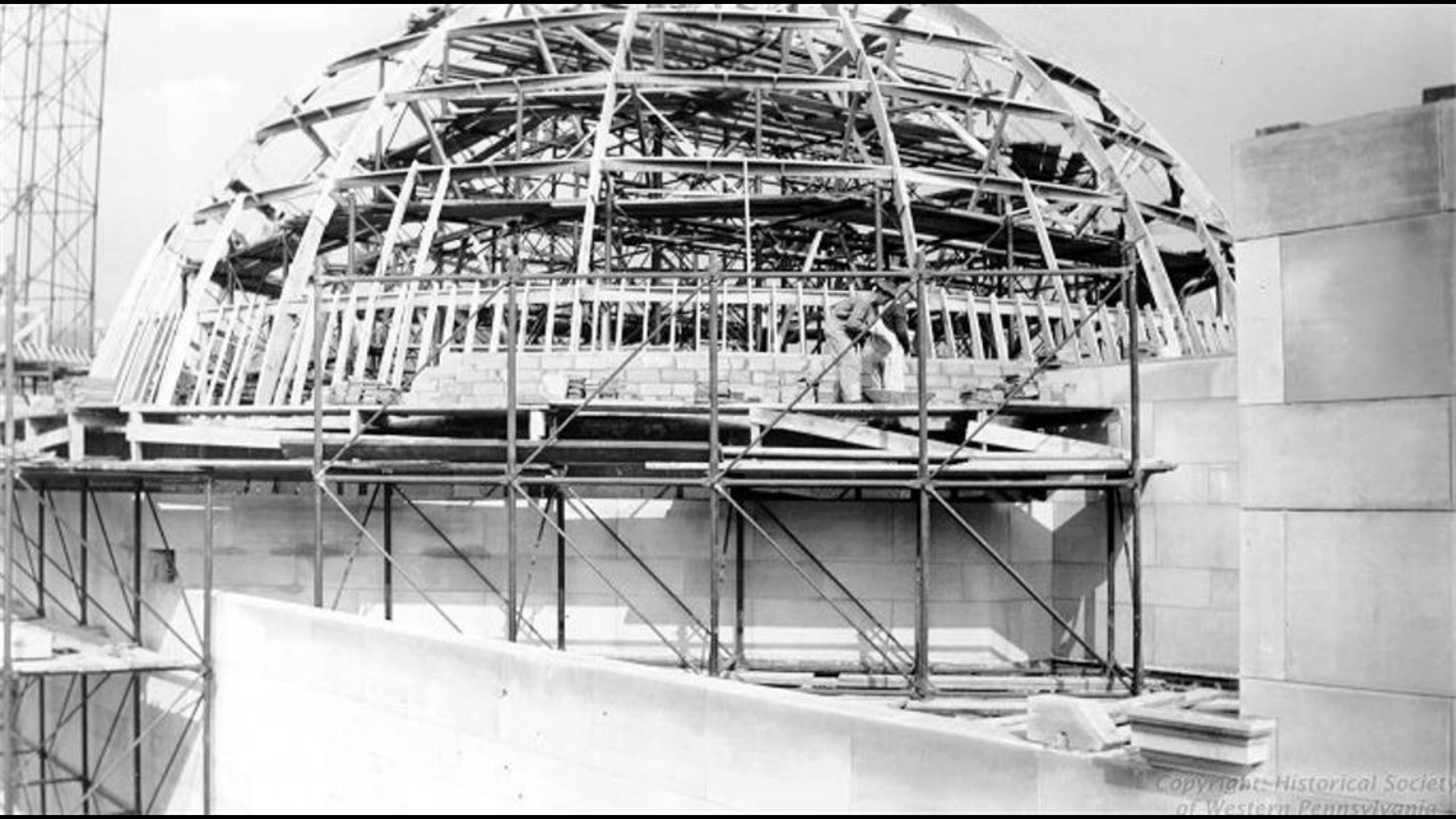
See our catalog in Sweet's

BUHL PLANETARIUM DOME
PITTSBURGH, PA.
INGHAM & BOYD, Architects

R. GUASTAVINO COMPANY
500 FIFTH AVE., NEW YORK 40 COURT ST., BOSTON









Copyrighted Material Society
of the Historical Photographers

ERLEI DE KROTA BILIA

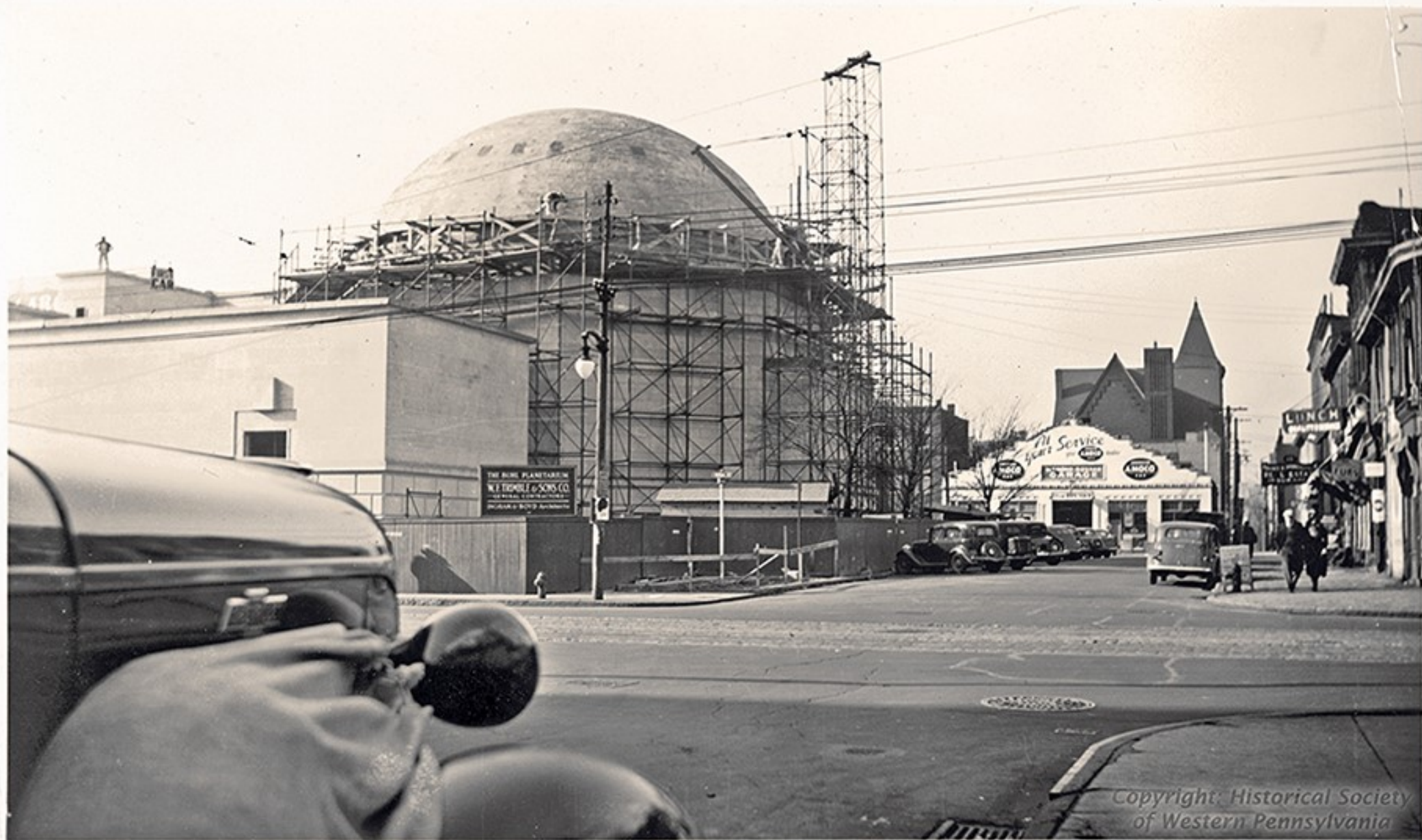
OCT 21 1938



*Copyright: Historical Society
of Western Pennsylvania*

THE PLANETARIUM

NOV 4 1938



Copyright: Historical Society
of Western Pennsylvania

BUHL PLANETARIUM

NOV 18 1938



Copyright: Historical Society
of Western Pennsylvania

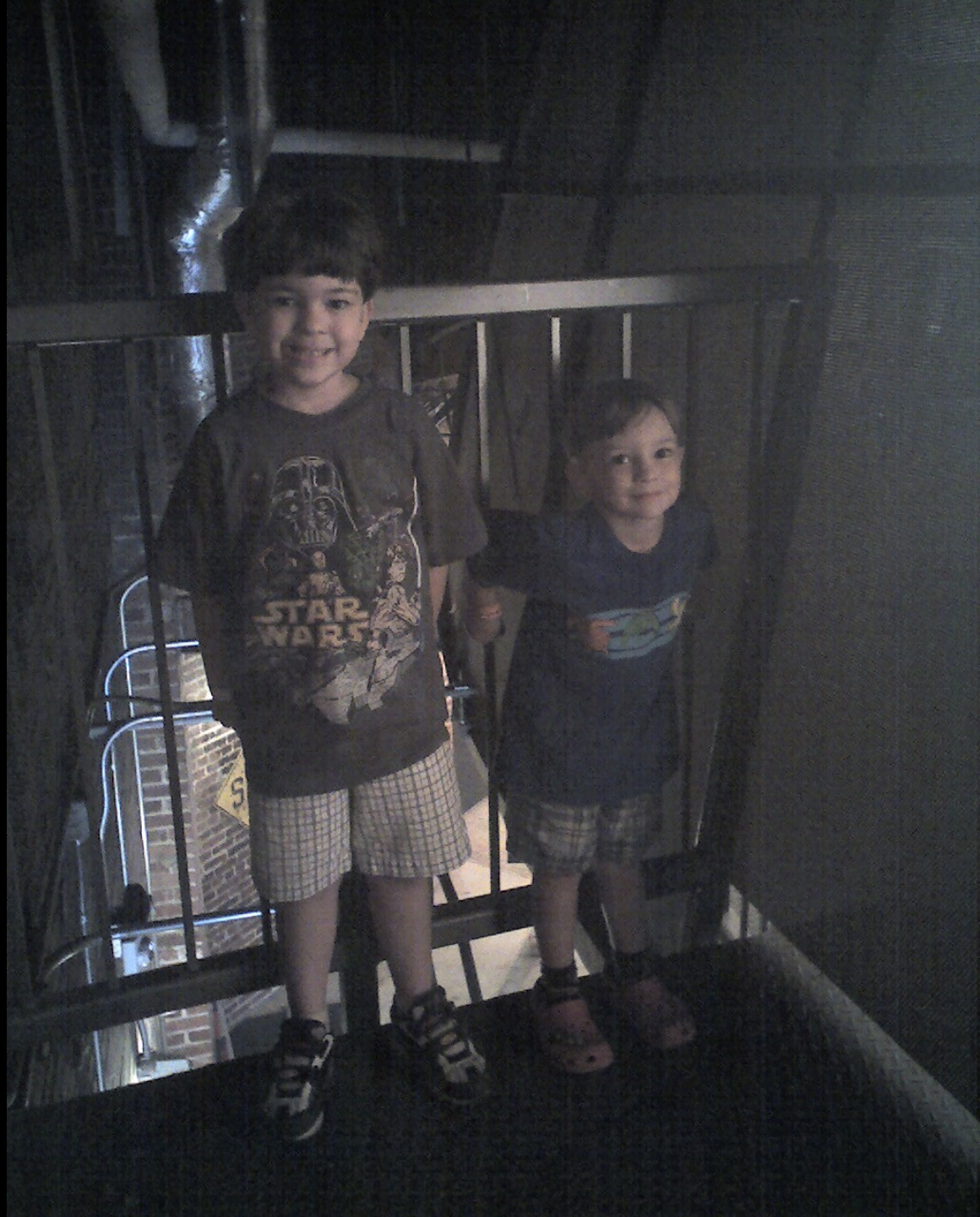
PHIPPS PLANETARIUM NOV 12 1938

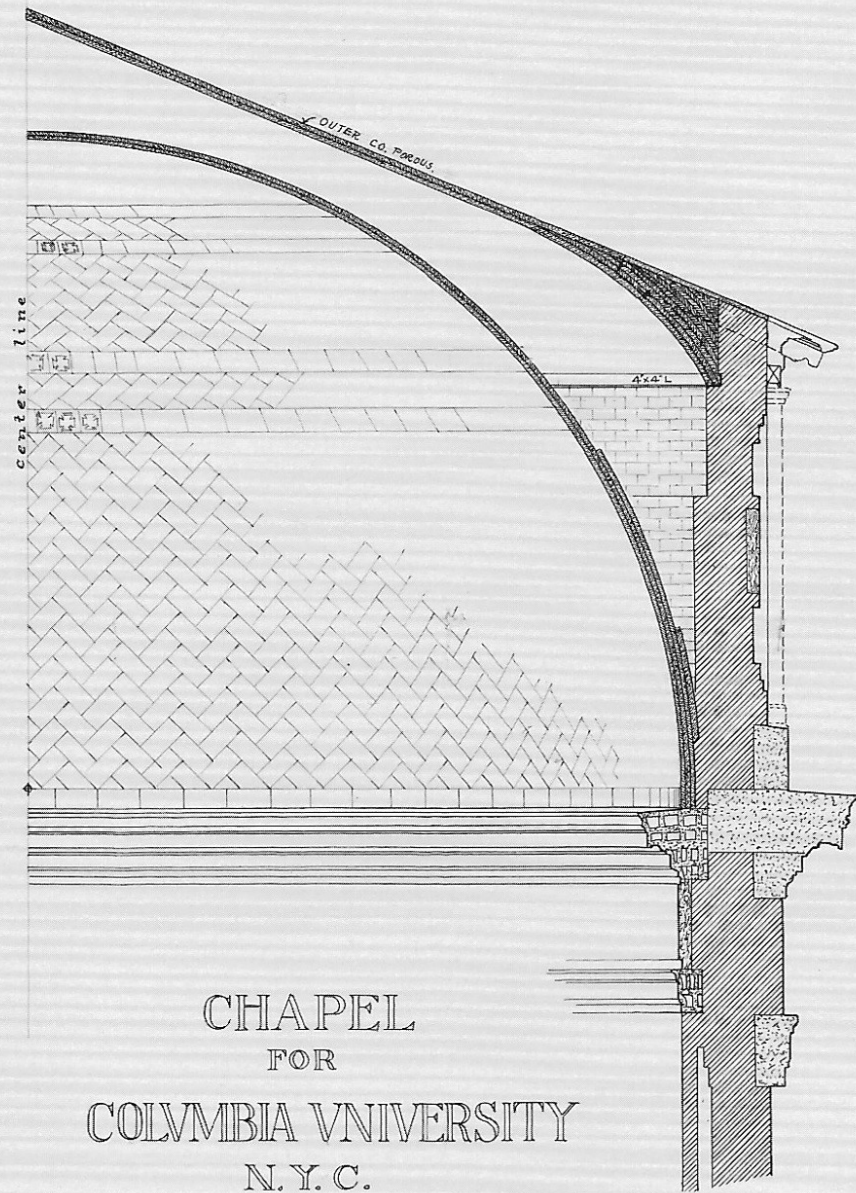


Photo: Mark Brueggjenjohann









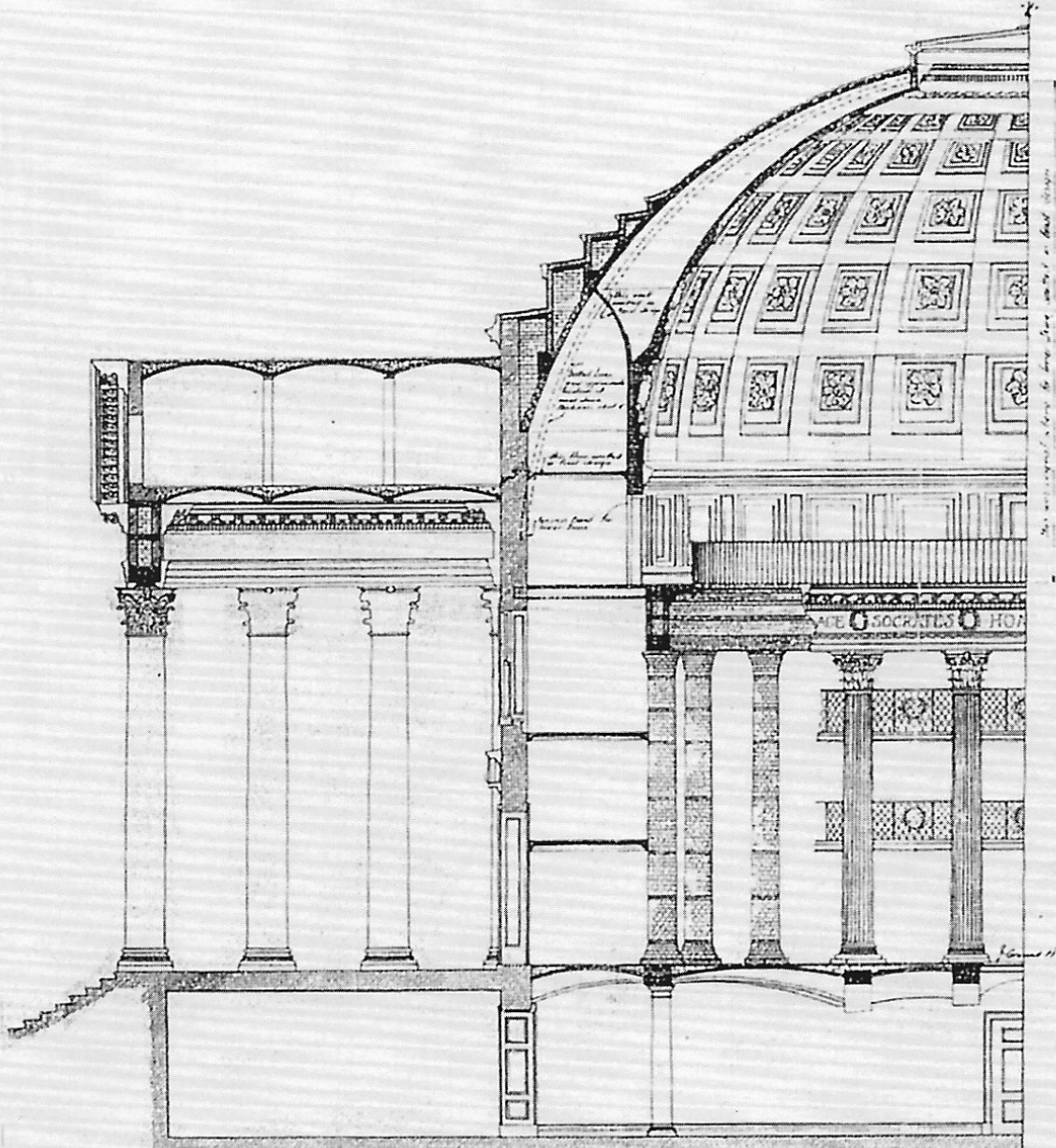
CHAPEL
FOR
COLUMBIA UNIVERSITY
N. Y. C.

½ INCH SECTION OF APSE

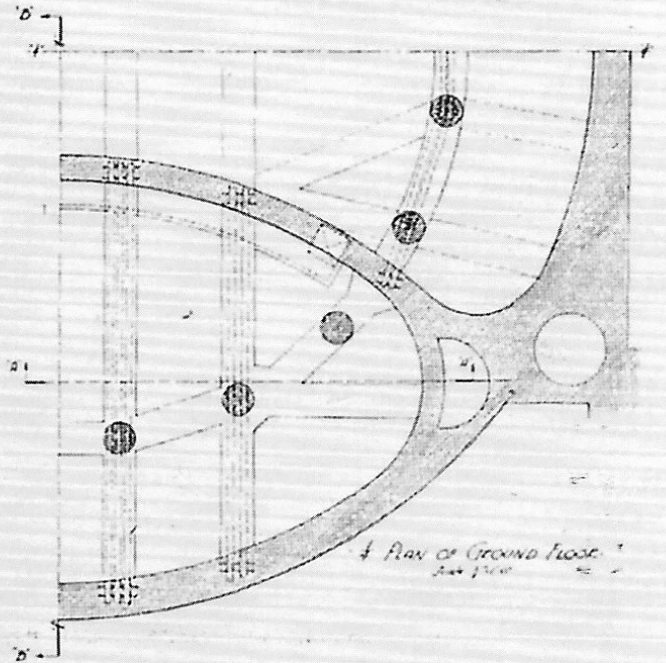
HOWELL & STOKES ARCHITECTS

R. GUASTAVINO CO.
NEW YORK
MAY 10TH 1905

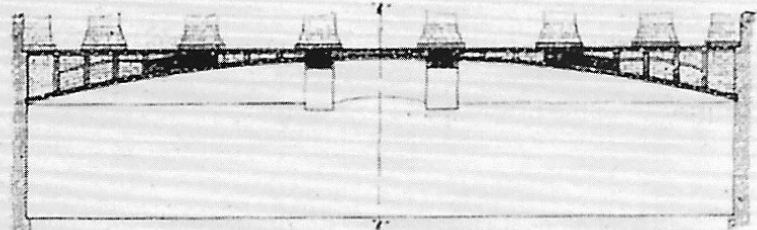
REVISED AUG. 16, 1905



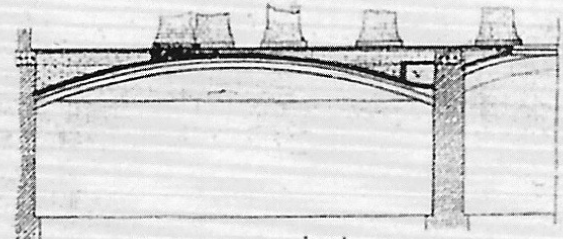
1/2 CROSS-SECTION THRU ROTUNDA DOMES
 SHOWING ORIGINAL SCHEME FOR INNER DOME AND INNER DOME AS
 CONSTRUCTED AS SHOWN BY DOTTED LINES. July 2, 1900



1/4 Plan of Ground Floor
 July 2, 1900



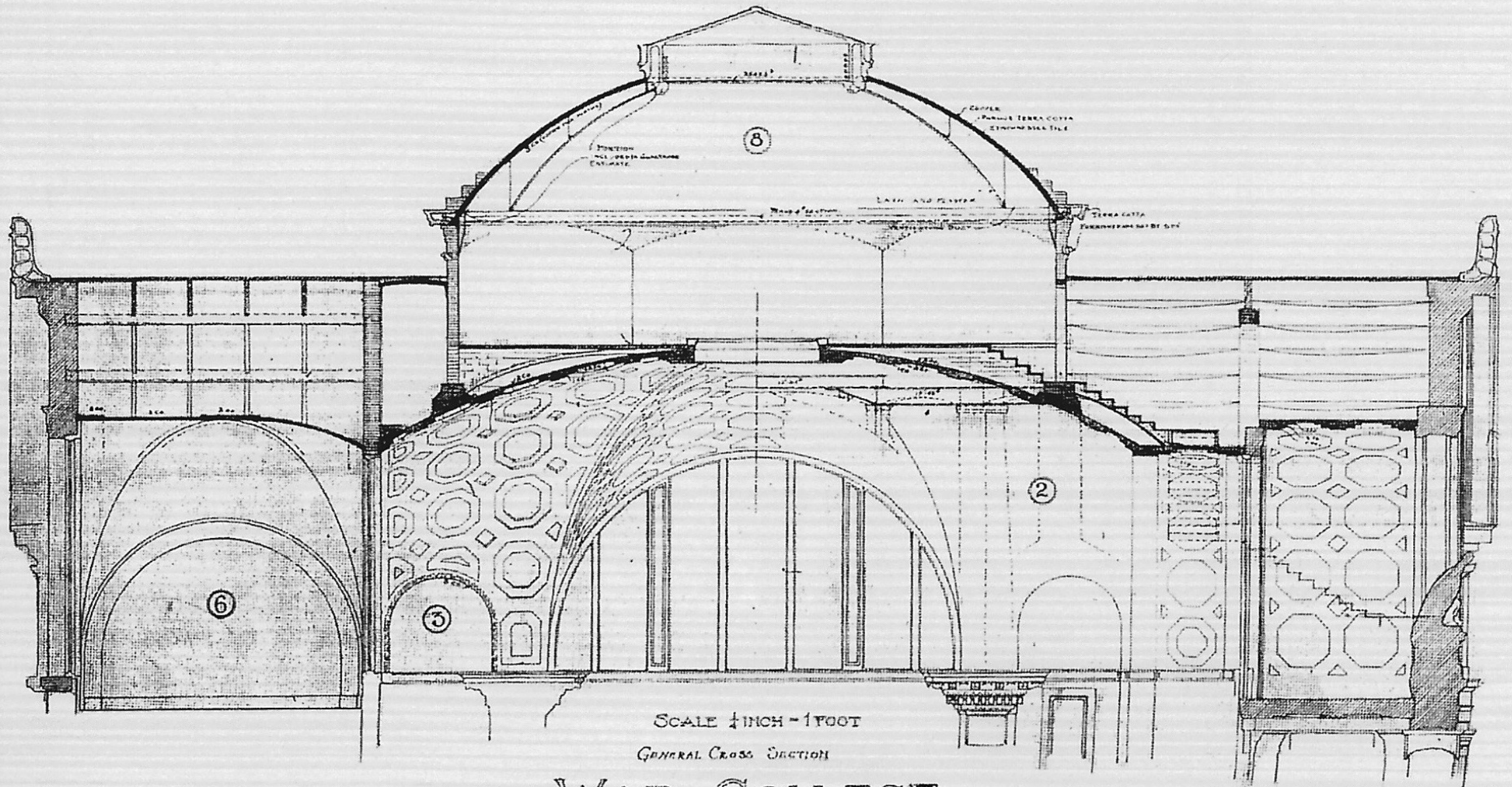
SECTION ON LINE 'AA'
 July 2, 1900



SECTION ON LINE 'BB'
 July 2, 1900

ROTUNDA DOMES
 UNIVERSITY OF VIRGINIA
 CHARLOTTESVILLE, VA. B. L. W. HEAD & PARTNERS

DESIGNED BY
 R. GUASTAVINO
 550 FIFTH AVENUE
 NEW YORK CITY



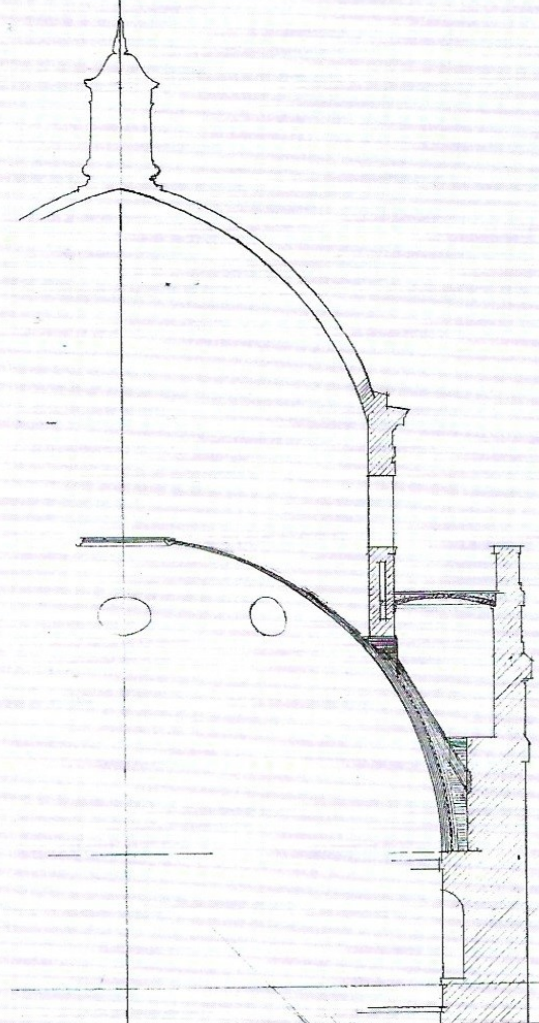
SCALE 1/4 INCH = 1 FOOT

GENERAL CROSS SECTION

WAR COLLEGE

Mc KIM MEAD & WHITE ARCHTS
NEW YORK

R. GUASTAVINO CO
 NEW YORK
 APRIL 7 - 1908



DIAGONAL SECTION
THRO DOME.

Scale $\frac{1}{4}'' = 1'-0''$

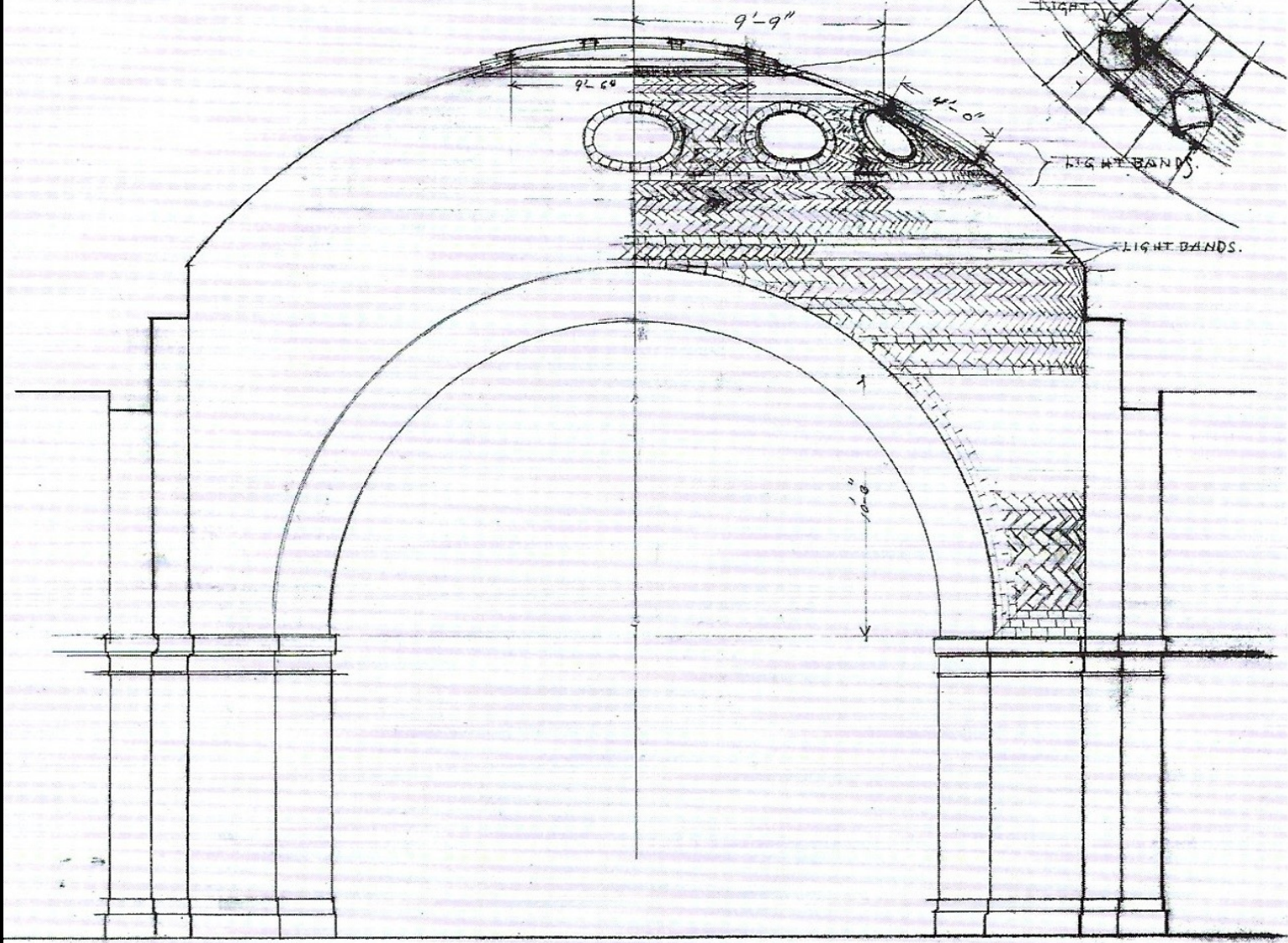
PLAN

Elephant house.

March 3 08

R. GASTAYINO Co.
N.Y. MAR 27 1908.

~ ELEPHANT HOUSE ~



~ ROTUNDA - CROSS SECTION ~

SCALE $\frac{1}{4}$

R. GASTAYINO Co.
FEB 27 1908.



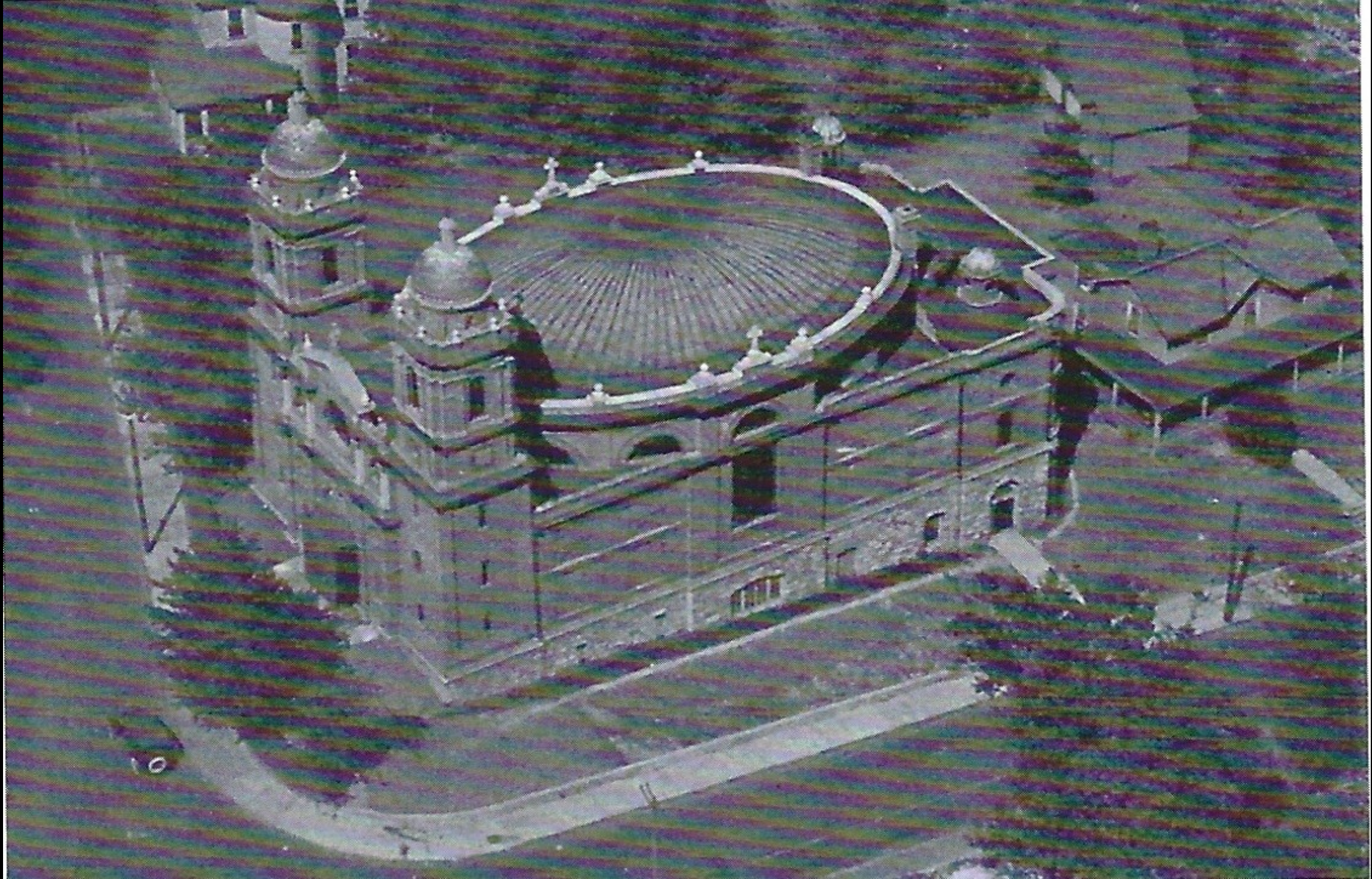




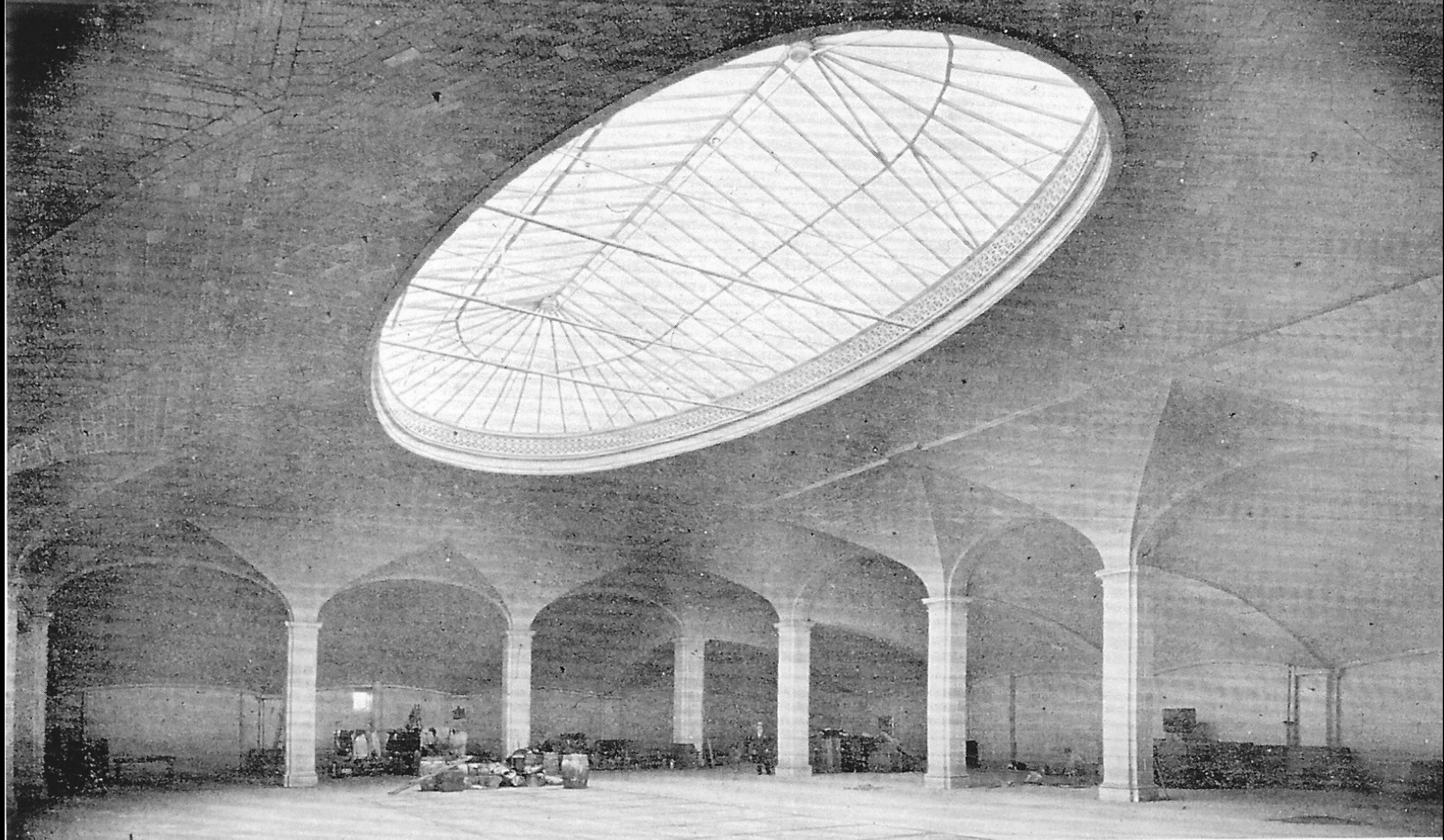




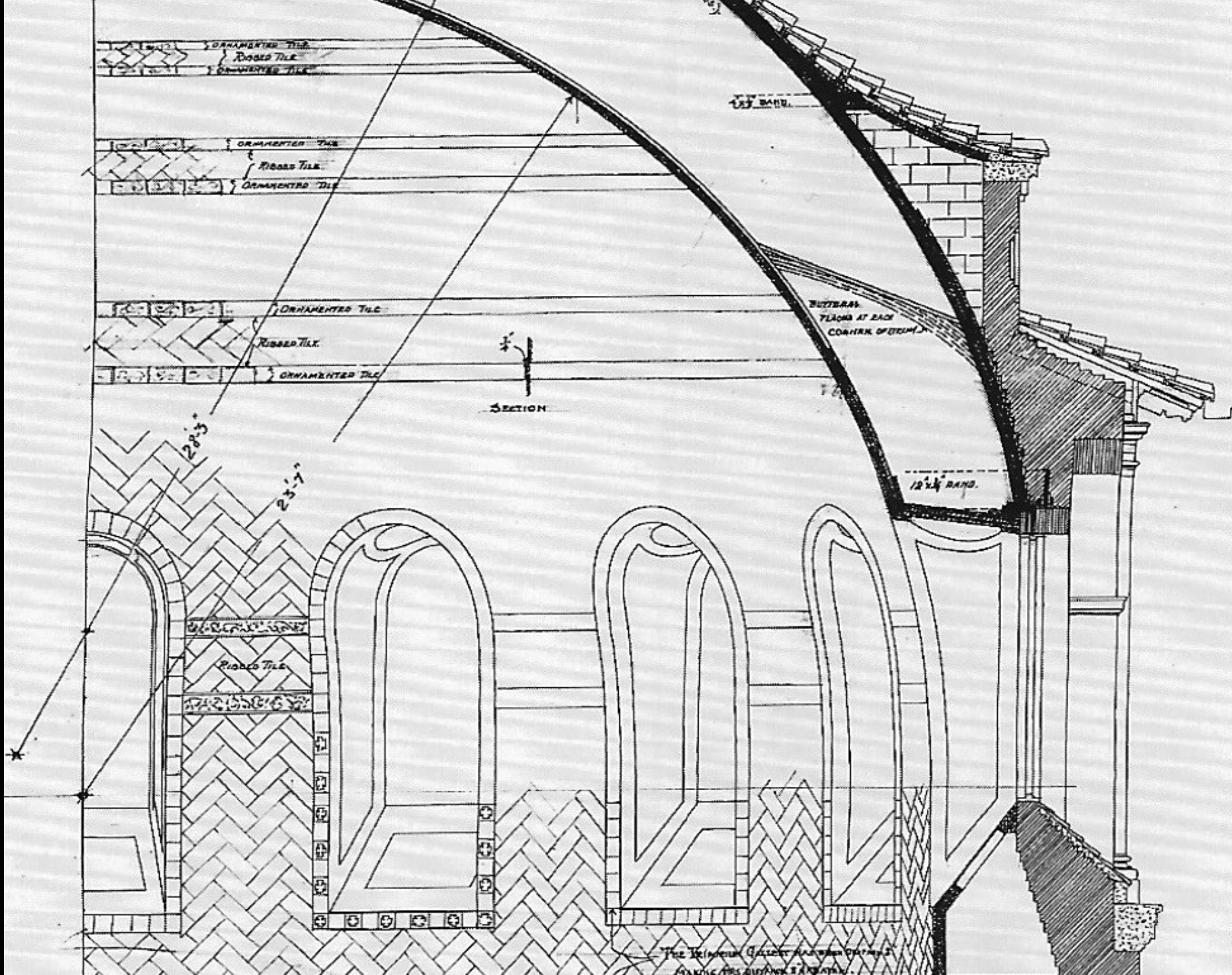












ORNAMENTED TILE
RIBBED TILE
CONCRETE TILE

ORNAMENTED TILE
RIBBED TILE
ORNAMENTED TILE

ORNAMENTED TILE
RIBBED TILE

ORNAMENTED TILE

SECTION

12 1/4\"/>

BUTTERFLY
FLANGES AT EACH
CORNER OF TRUSS

12 1/4\"/>

29 3/4"

25 1/2"

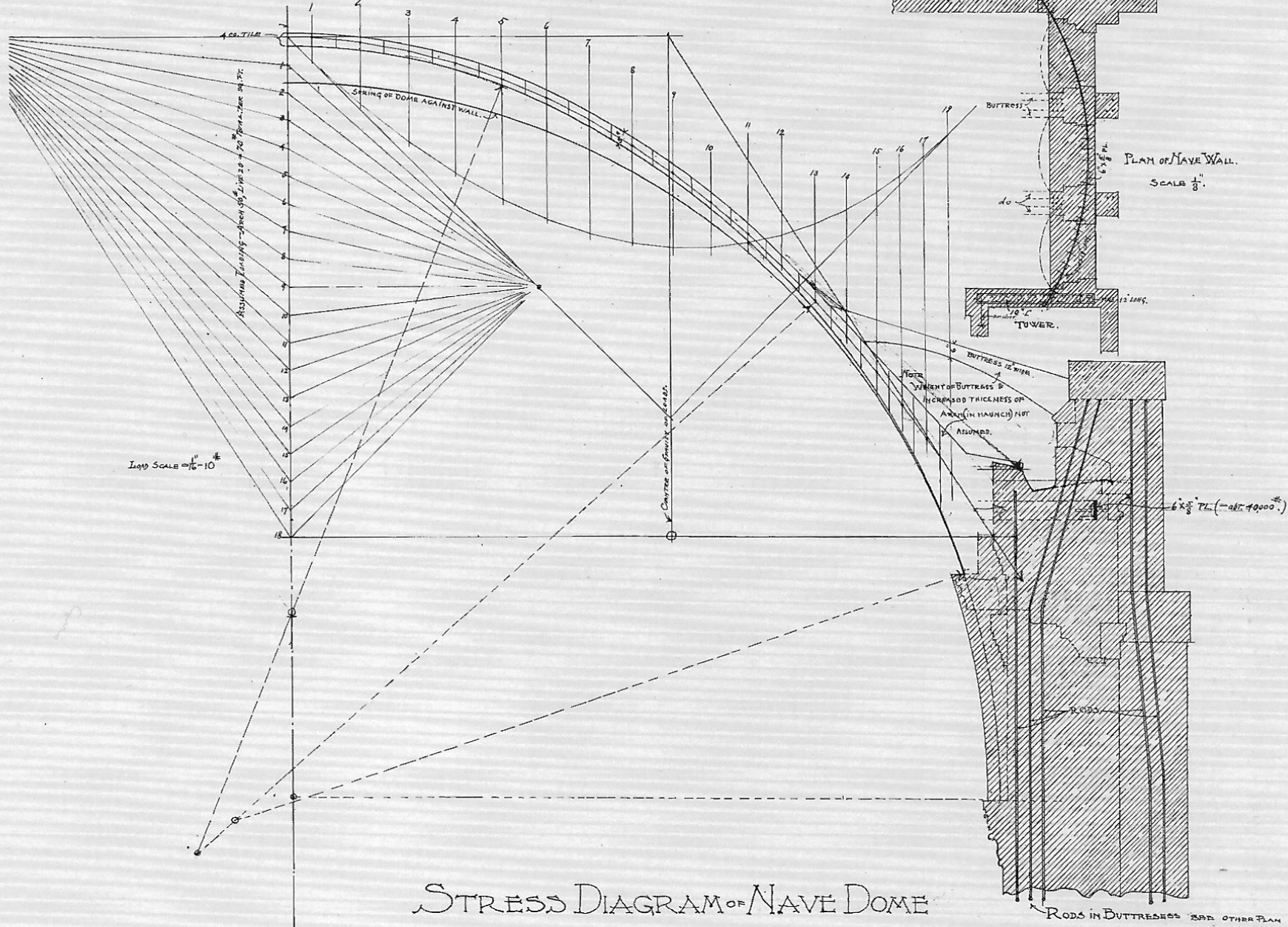
ORNAMENTED TILE

RIBBED TILE

ORNAMENTED TILE

THE BRIMMER GALLERY AND THE CHURCH
MADE BY THE BRIMMER GALLERY

ST. FRANCIS DE SALES CHURCH
 47 $\frac{1}{2}$ SPRINGFIELD AVE. PHILADELPHIA PA. HENRY D. DAGIT ARCHT.



LONG SCALE = $\frac{1}{16}$ - 10"

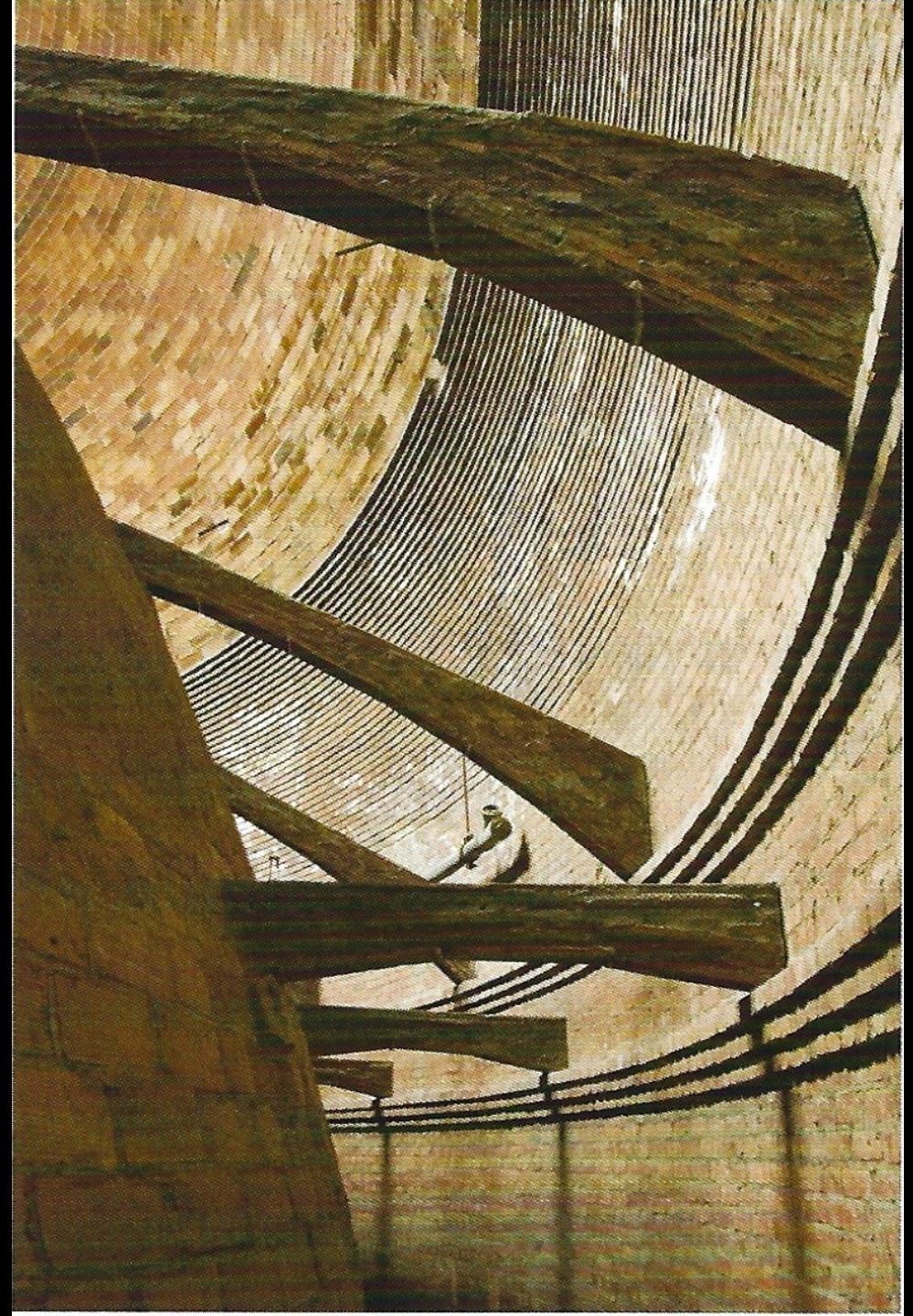
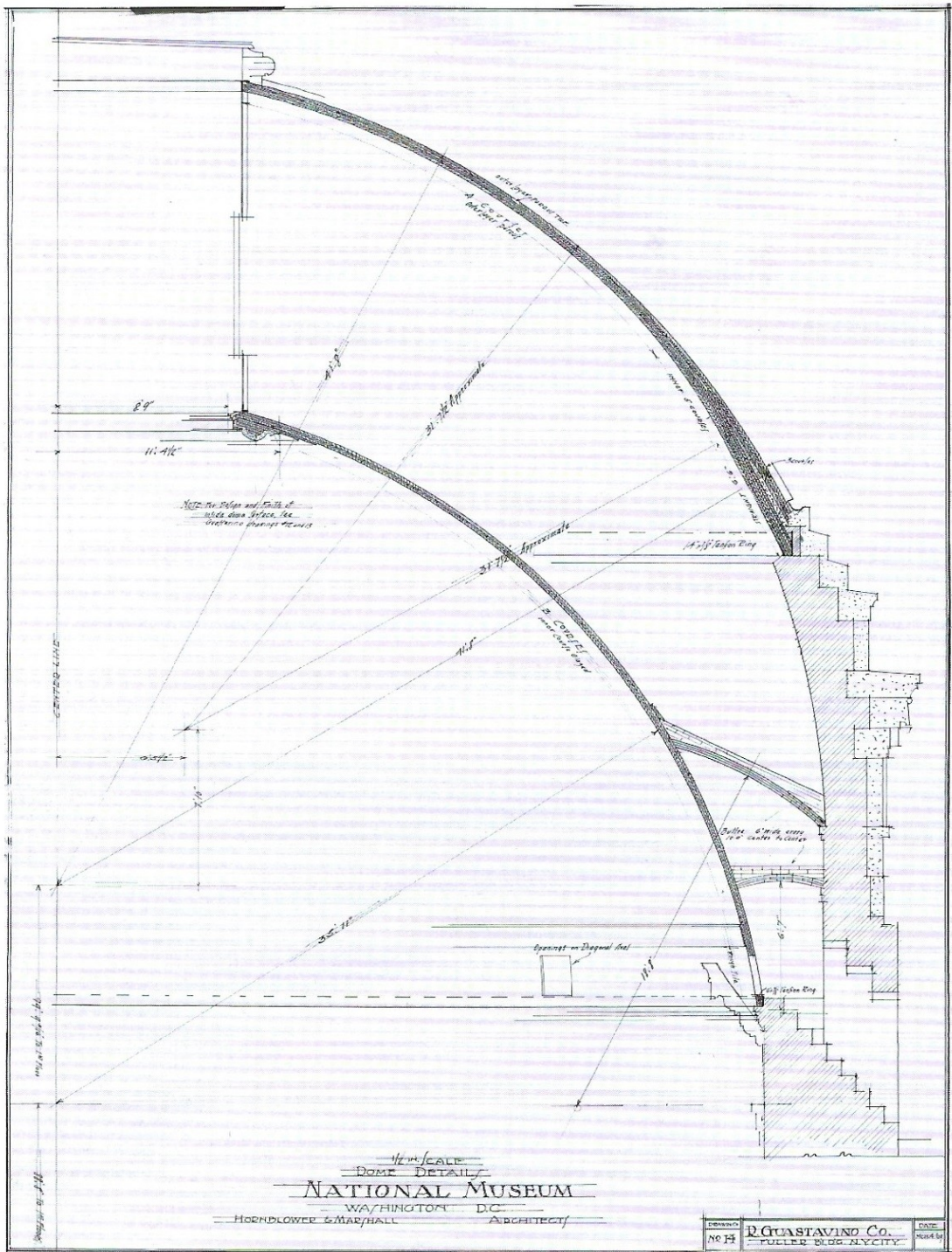
PLAN OF NAVE WALL.
 SCALE $\frac{1}{8}$ "

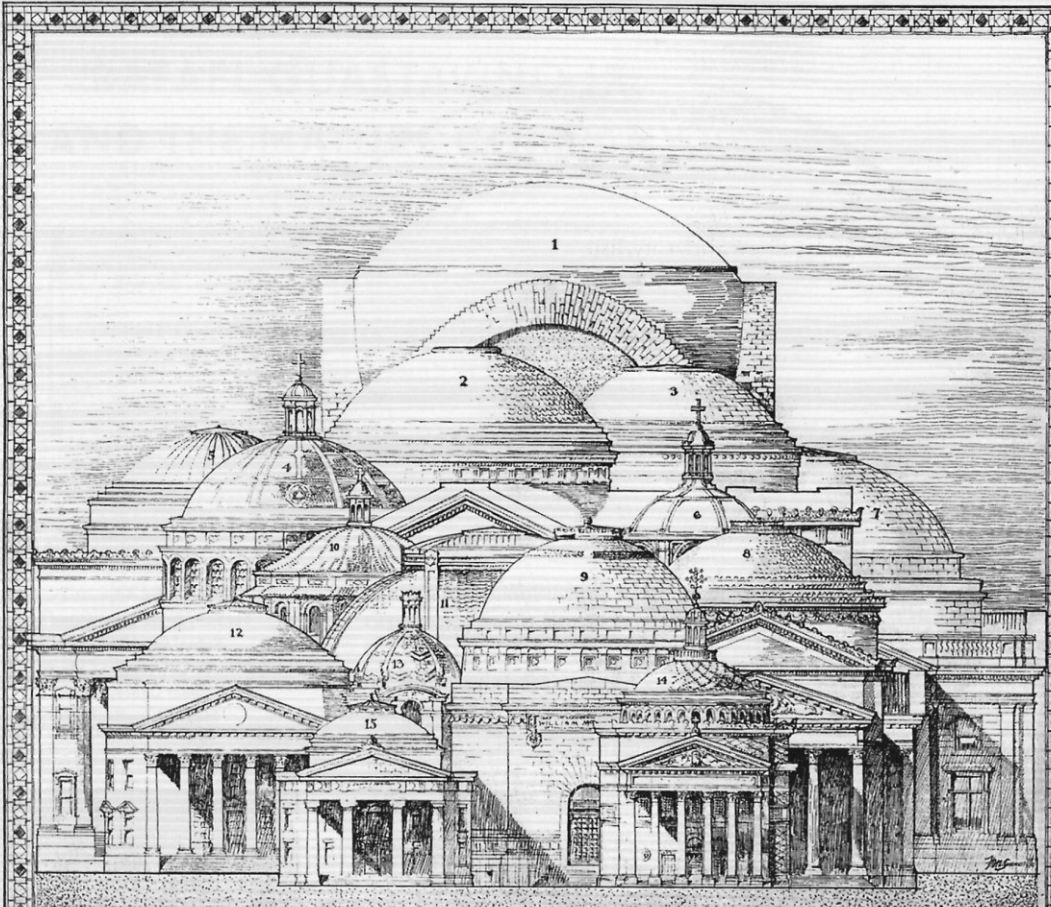
STRESS DIAGRAM OF NAVE DOME

ASSUMED WIDTH OF ONE FOOT
 SCALE $\frac{3}{8}$ " ONE FOOT

4

R. GUASTAVINO CO.
 APRIL 13 1908
 FULLER BLDG N.Y.C.



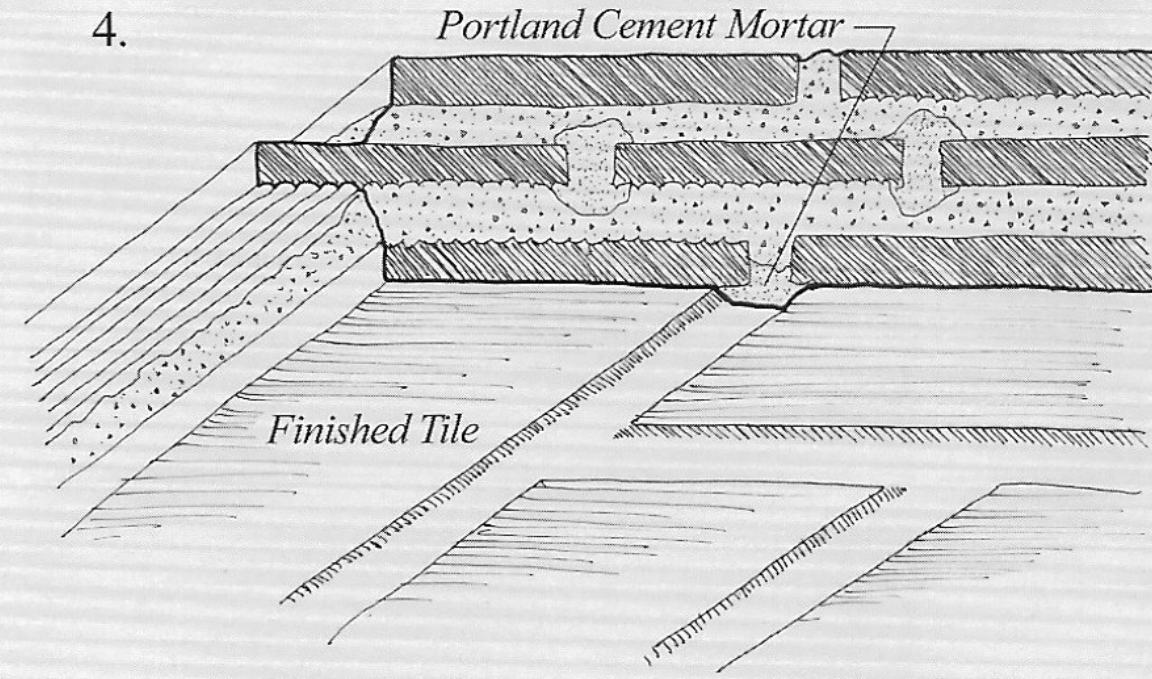
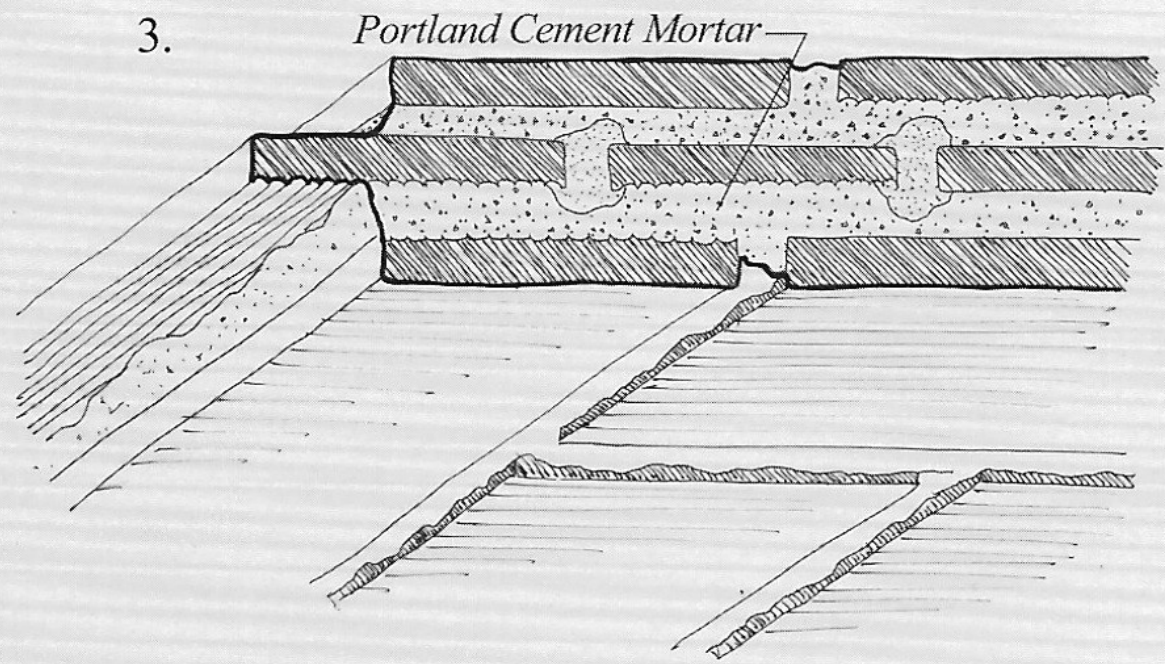
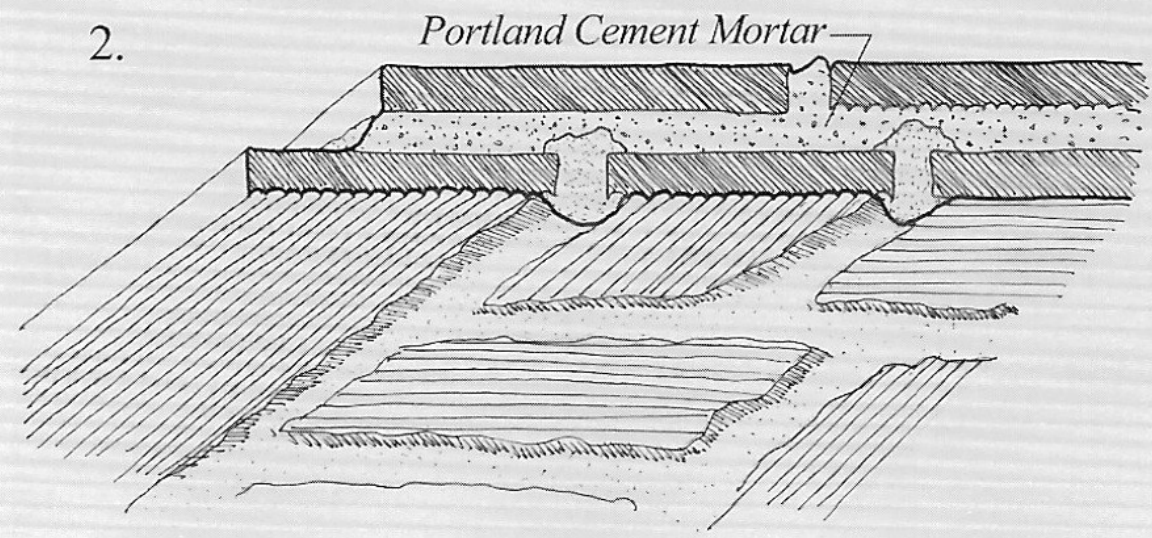
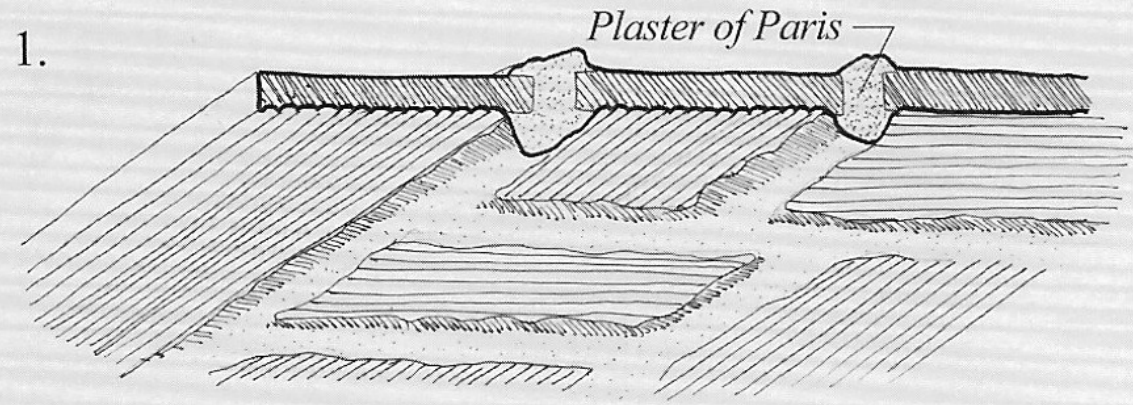


**SOME DOMES CONSTRUCTED BY
R. GUASTAVINO CO.**

BOSTON

NEW YORK

| BUILDING and LOCATION | SPAN | ARCHITECTS | BUILDING and LOCATION | SPAN | ARCHITECTS |
|--|-----------------|--|--|----------------|------------------------|
| 1. Cathedral, St. John the Divine, New York City | 135 ft. at base | Heins & La Farge | 8. University of New York, New York City | 70 ft. at base | McKim, Mead & White |
| 2. National Museum, Washington, D. C. | 80 | Hornblower & Marshall | 9. McKinley National Memorial, Canton, Ohio | 56 | H. Van Buren Magonigle |
| 3. Institute of Arts and Sciences, Brooklyn, N. Y. | 64 | McKim, Mead & White | 10. St. Paul's Chapel, Columbia U., N. Y. City | 52 | Howells & Stokes |
| 4. St. Francis de Sales Church, Philadelphia, Pa. | 61 | Henry D. Dagit | 11. Rodef Sholem Synagogue, Pittsburgh, Pa. | 50 | Palmer & Hornbostel |
| 5. Bank of Montreal, Montreal, P. Q. | 69 | McKim, Mead & White | 12. University of Virginia, Charlottesville, Va. | 70 | McKim, Mead & White |
| 6. Church of St. Barbara, Brooklyn, N. Y. | 43 | and A. T. Taylor | 13. Elephant House, Bronx Park, New York City | 34 | Heins & La Farge |
| 7. Girard Trust Company, Philadelphia, Pa. | 101 | Helme & Hubert | 14. Madison Sq. Presby'n Church, N. Y. City | 46 | McKim, Mead & White |
| | | McKim, Mead & White and Allen Evans | 15. J. J. Jermain Memorial Library, Sag Harbor, N. Y. | 30 | Augustus N. Allen |













SECTION ON LINE G-H • A
 SCALE 1/4" = 1'-0"

KEY.

| | |
|------------------------------------|----------|
| RANDOM ASHLAR | [Symbol] |
| DIMENSION STONE | [Symbol] |
| CUT STONE | [Symbol] |
| BRICK | [Symbol] |
| QUARTZITE VAULTING | [Symbol] |
| CONCRETE | [Symbol] |
| WOOD | [Symbol] |
| WOOD PARTITIONS AND WOOD FURRING | [Symbol] |
| METAL | [Symbol] |
| LINE STONE SHOWN IN COLOR IN ELEV. | [Symbol] |

SAND -
LIME
BRICK.

7'-0"

3-8-25ⁿ

FLASHING

GUASTAVINO VAULTING

2x8'-16" ac.

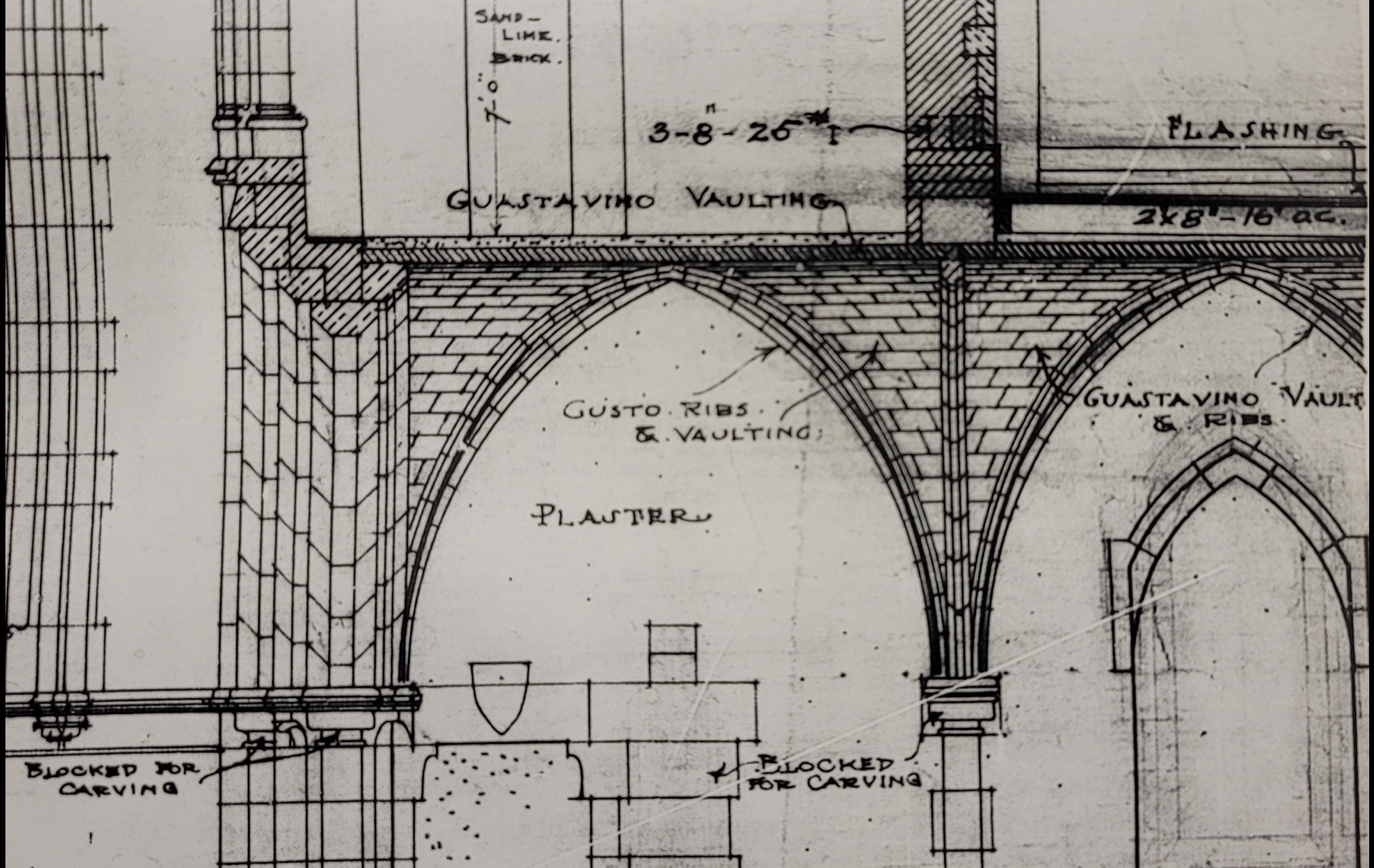
GUSTO RIBS
& VAULTING

GUASTAVINO VAULT
& RIBS

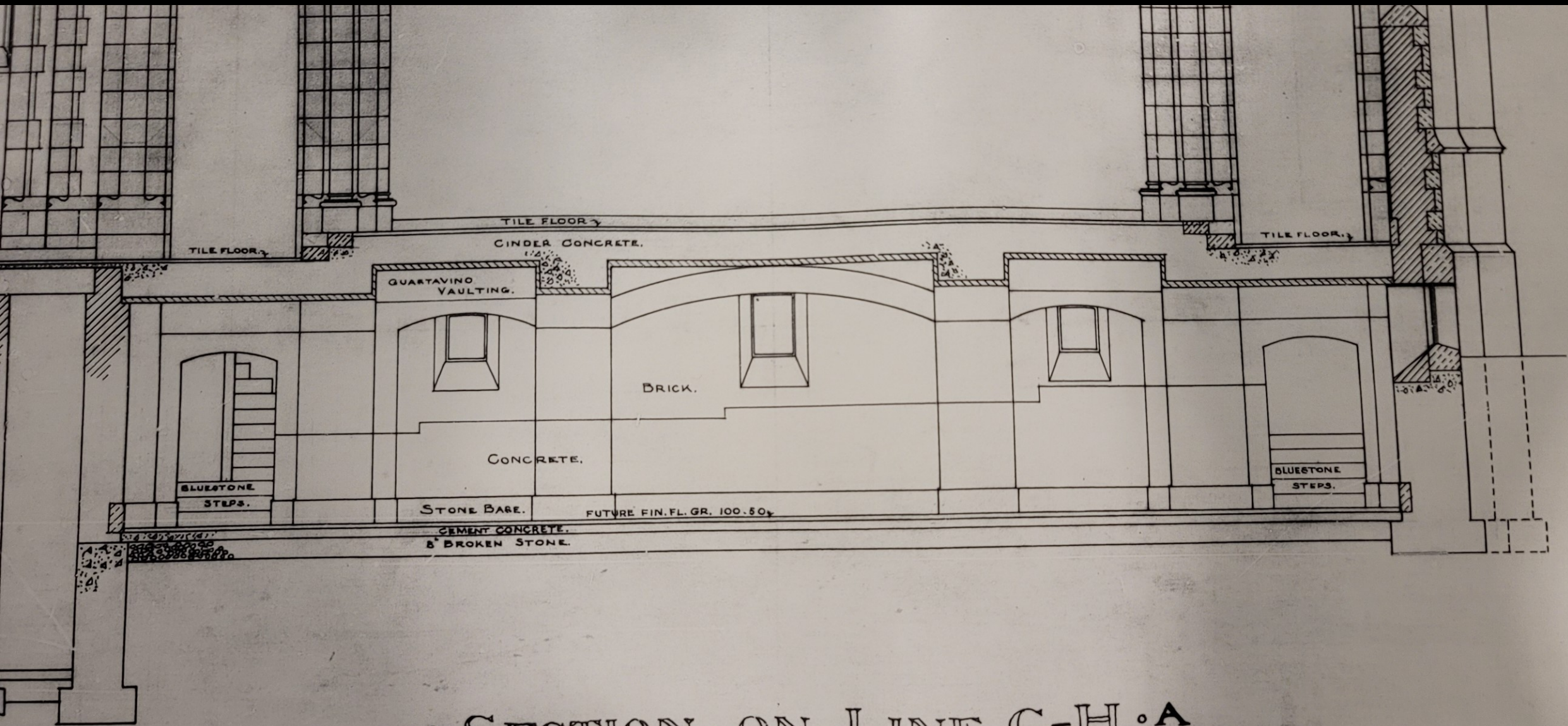
PLASTER

BLOCKED FOR
CARVING

BLOCKED
FOR CARVING







SECTION ON LINE G-H • A



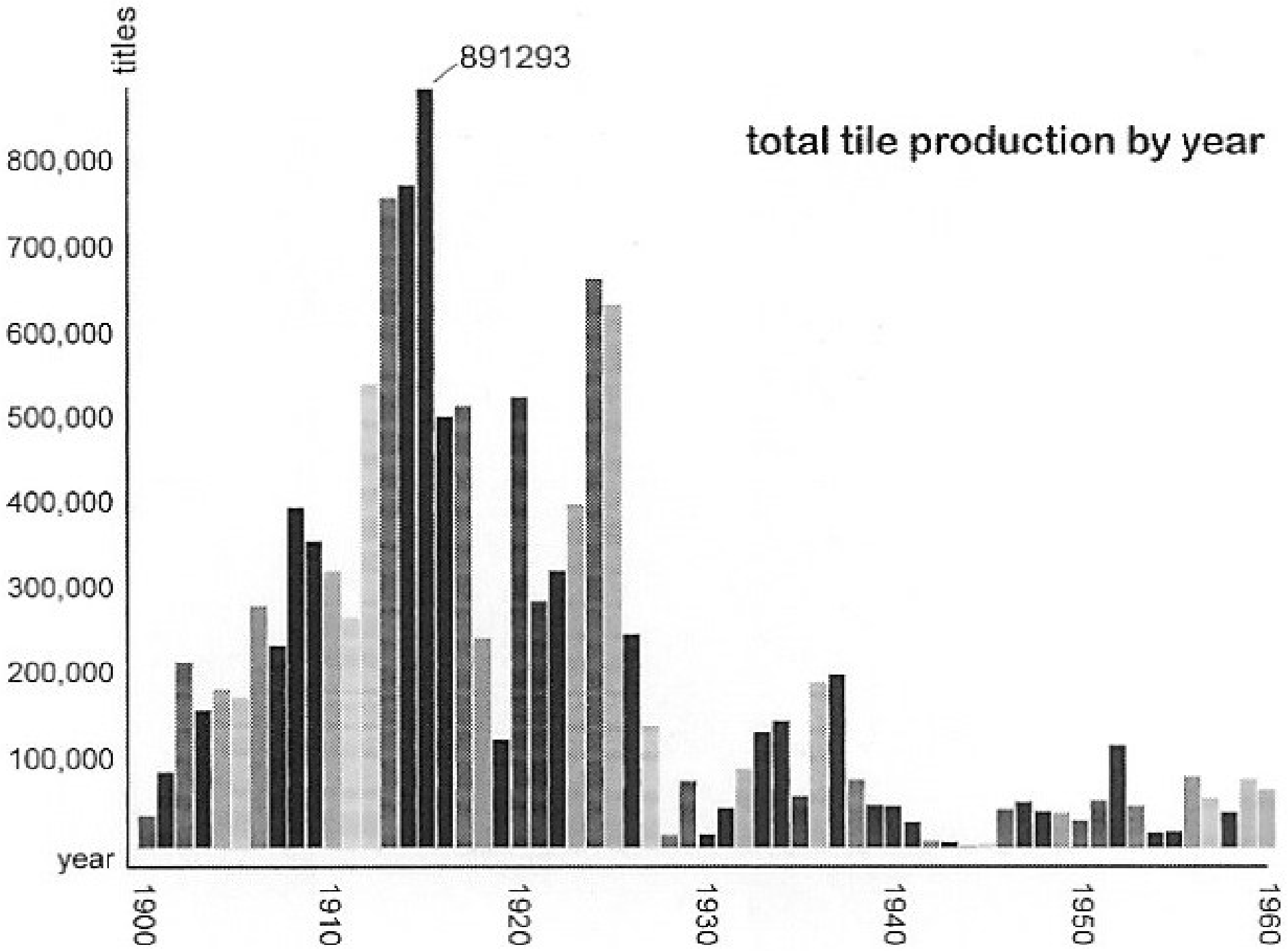










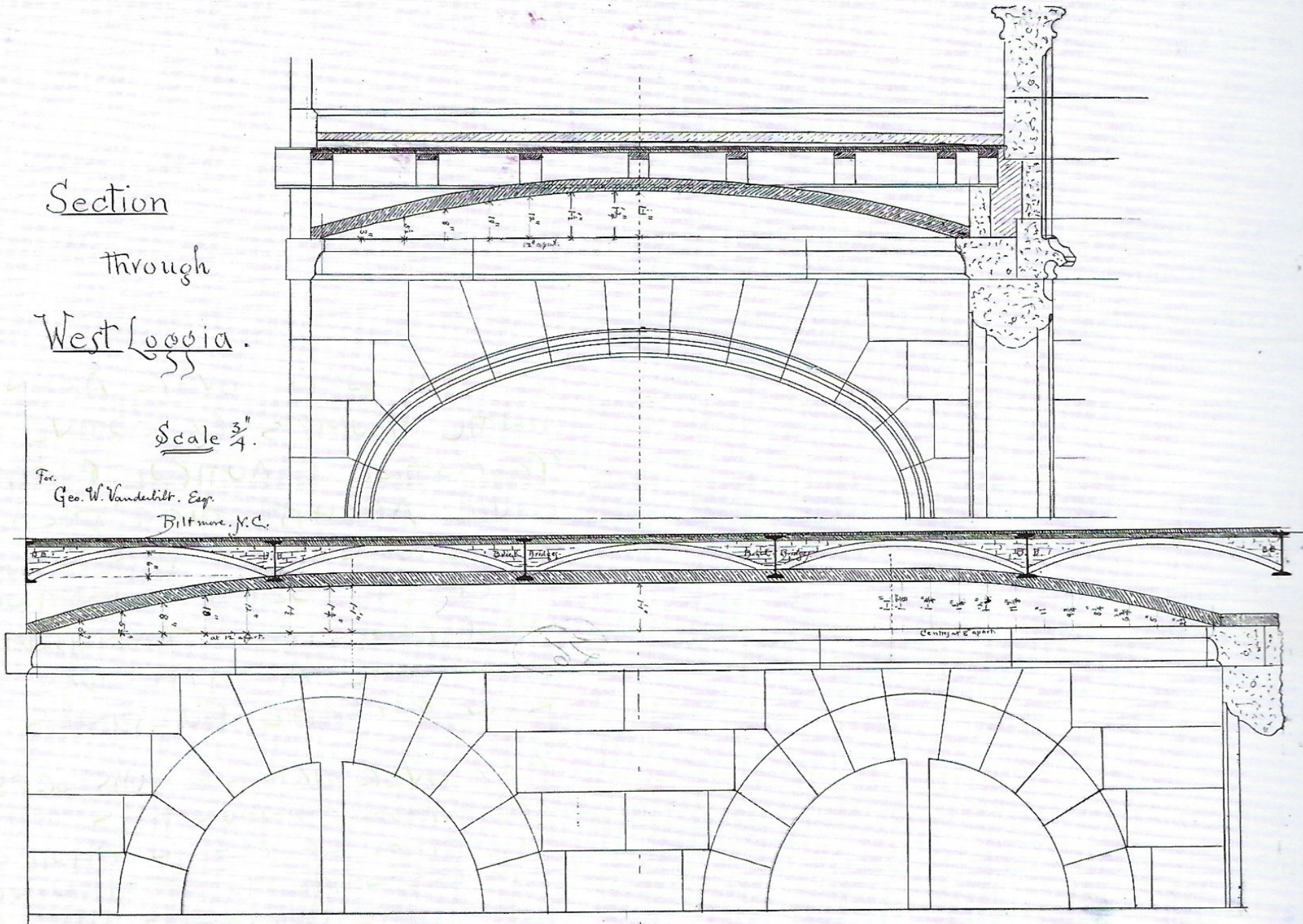




Section
through
West Loggia.

Scale $\frac{3}{4}$ "

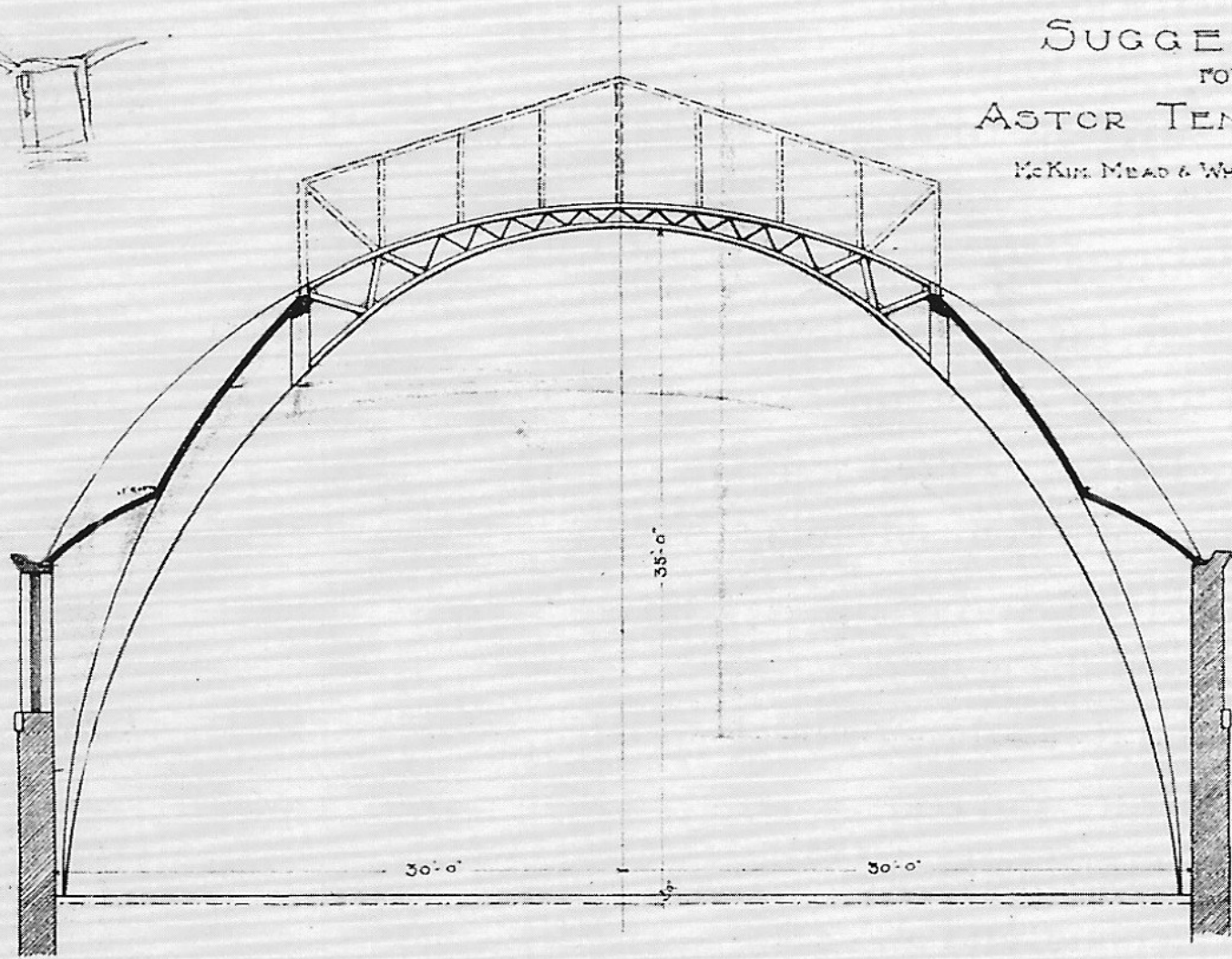
For
Geo. W. Vandeventer, Esq.
Biltmore, N.C.



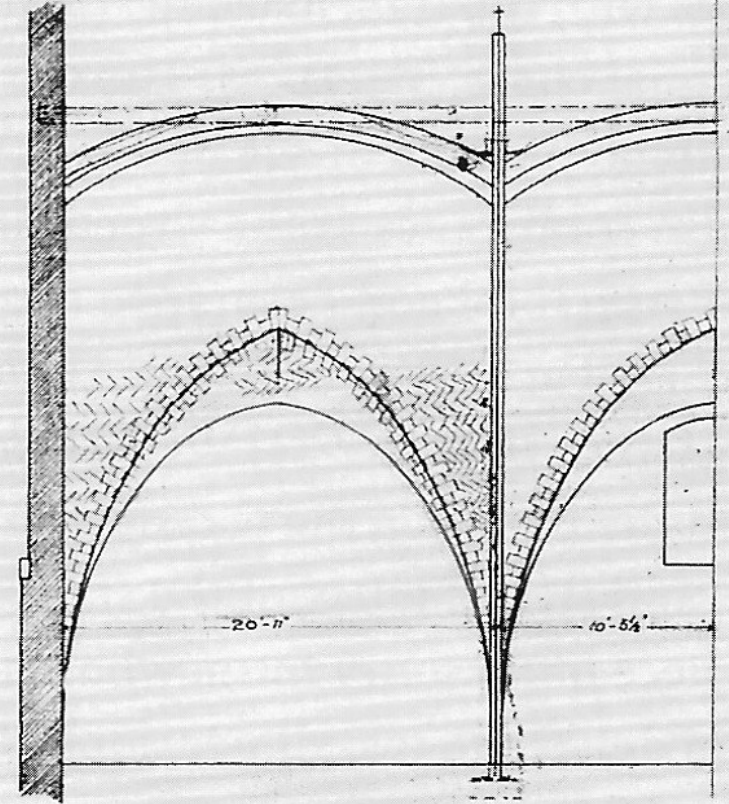


SUGGESTION
FOR
ASTOR TENNIS COURT

McKIM MEAD & WHITE ARCHITECTS.



CROSS SECTION



LONGITUDINAL SECTION

R. GUSTAVINO Co
NEW YORK
NOV 21 1904





iences



Charity Randall Theatre

Stephen Foster Memorial





RITY RANDALL THE

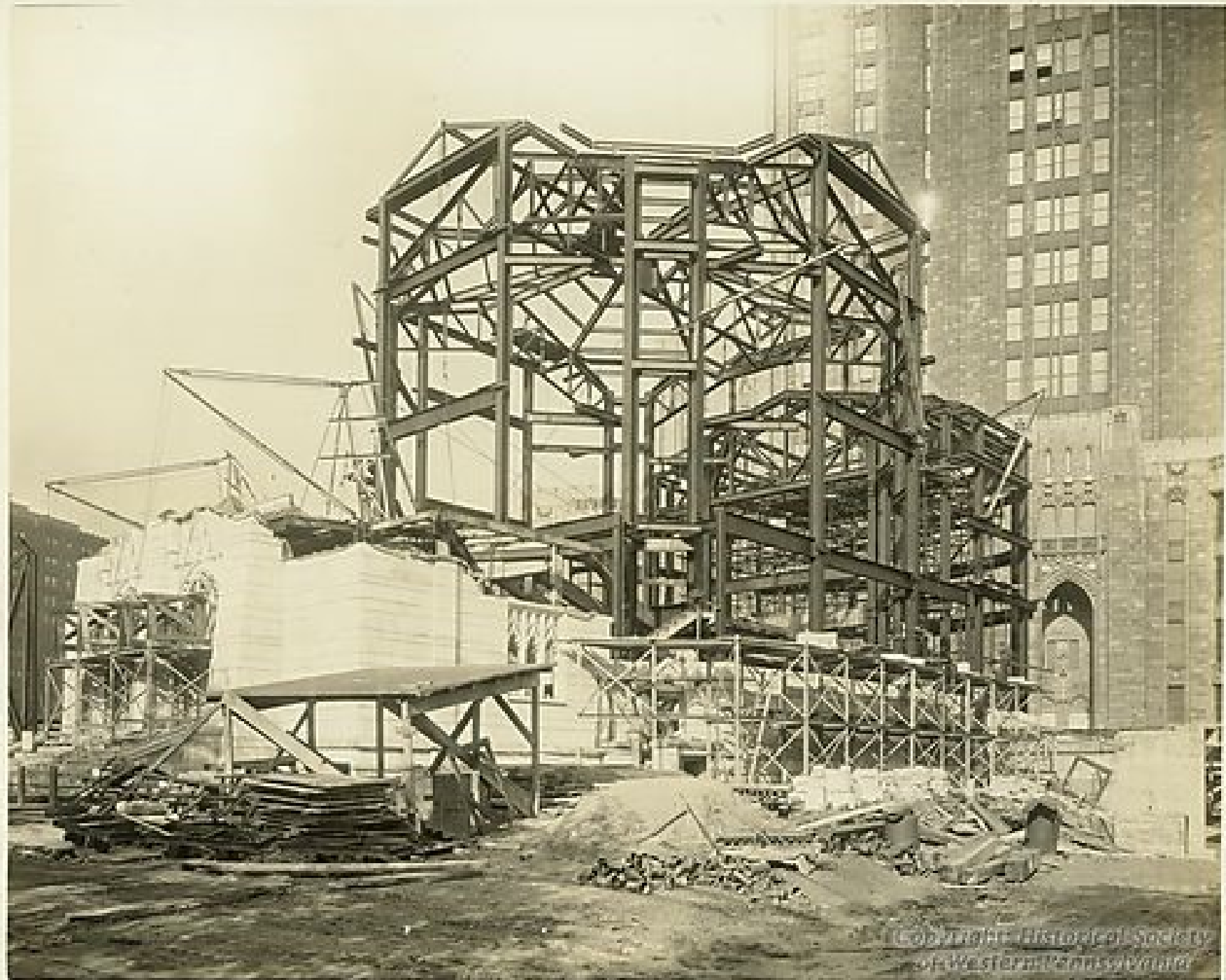


BALCONY 7

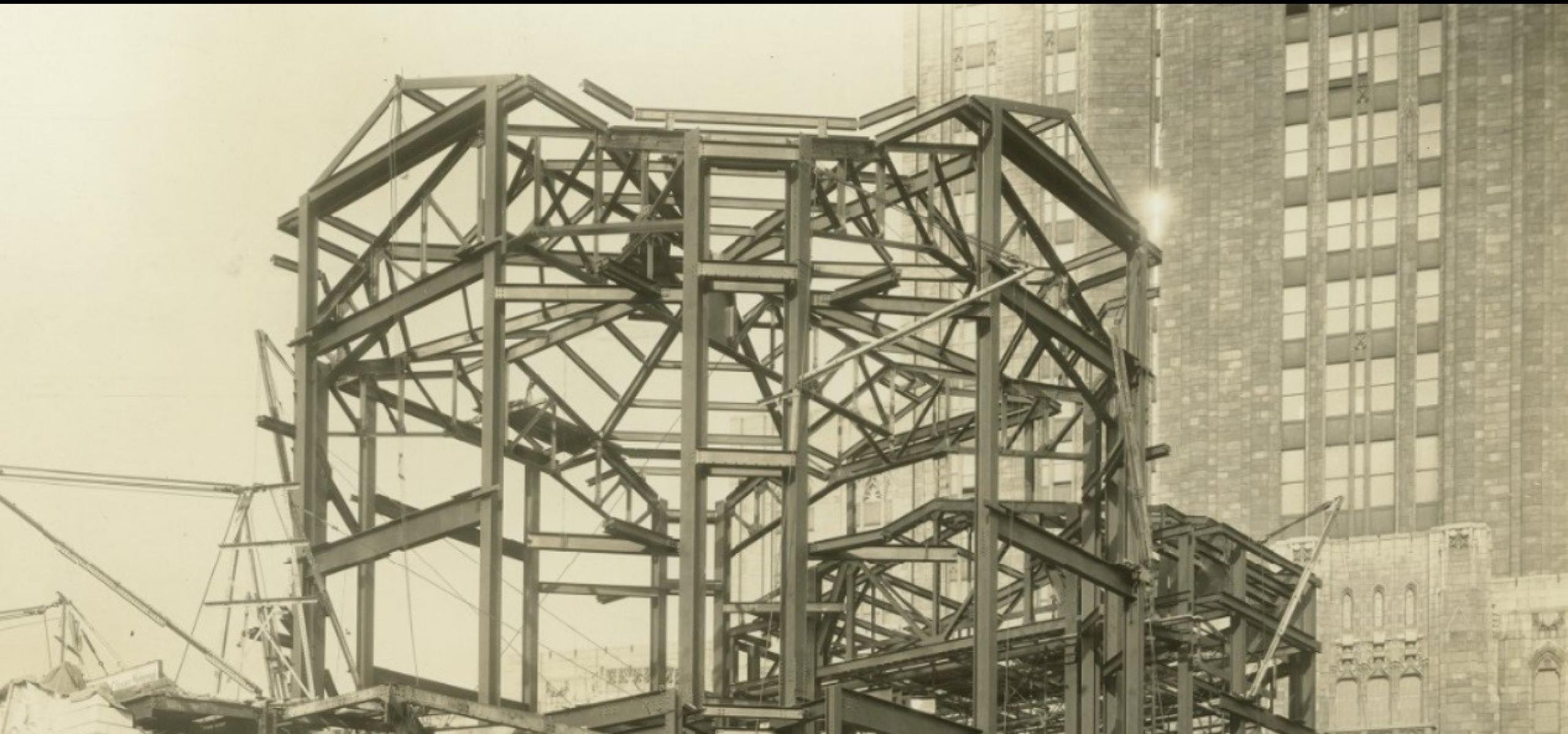
PLAY & DINING







Copyright Historical Society
of Western Missouri



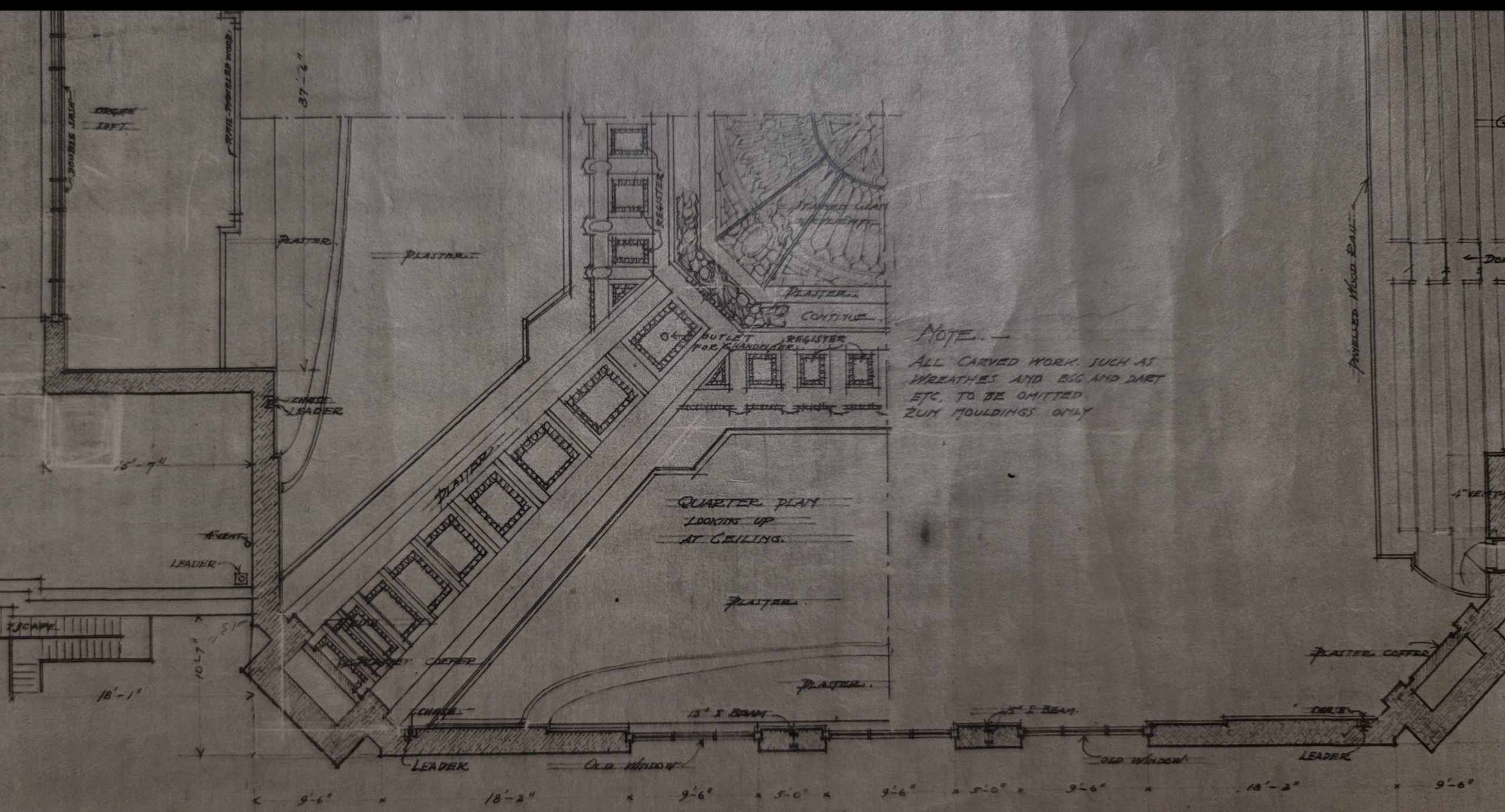








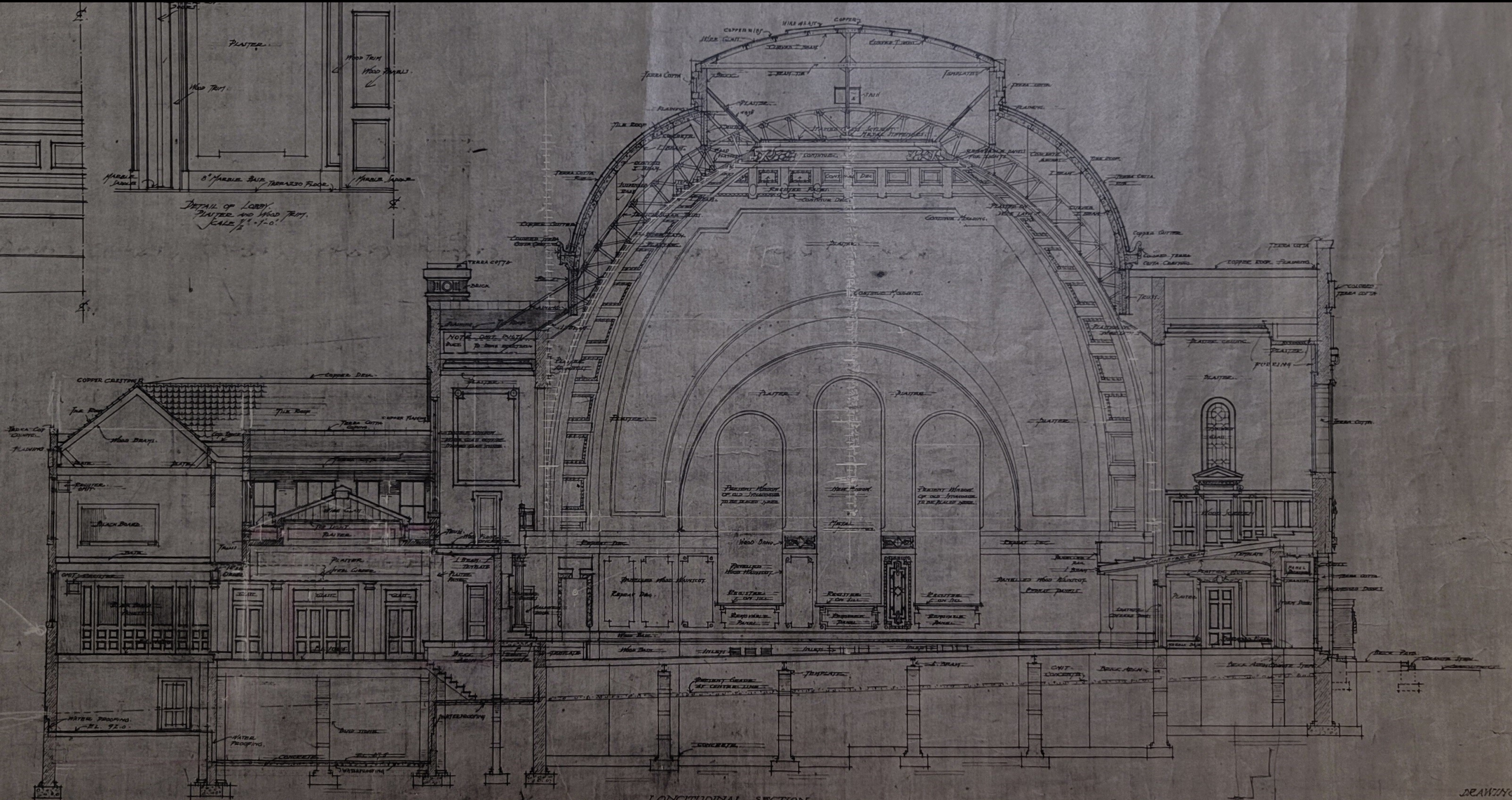




NOTE...
 ALL CARVED WORK, SUCH AS
 WREATHES AND EGG AND DART
 ETC. TO BE OMITTED.
 2" MOULDINGS ONLY

QUARTER PLAN
 LOOKING UP
 AT CEILING.

9'-6" x 18'-2" x 9'-6" x 5'-0" x 9'-6" x 5'-0" x 9'-6" x 13'-2" x 9'-6"



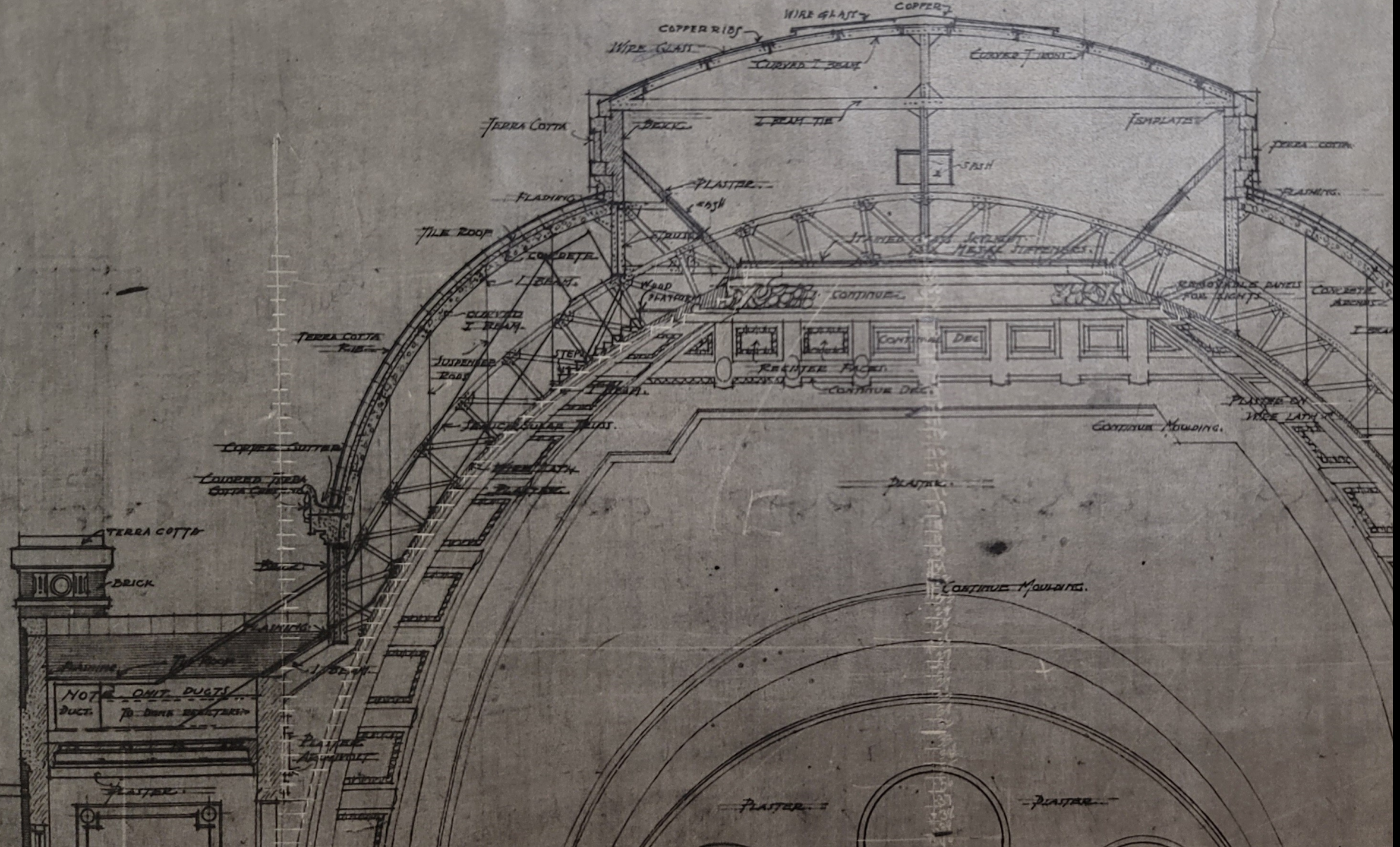
DETAIL OF LOBBY
PLASTER AND WOOD TRIM.
SCALE 1/2" = 1'-0"

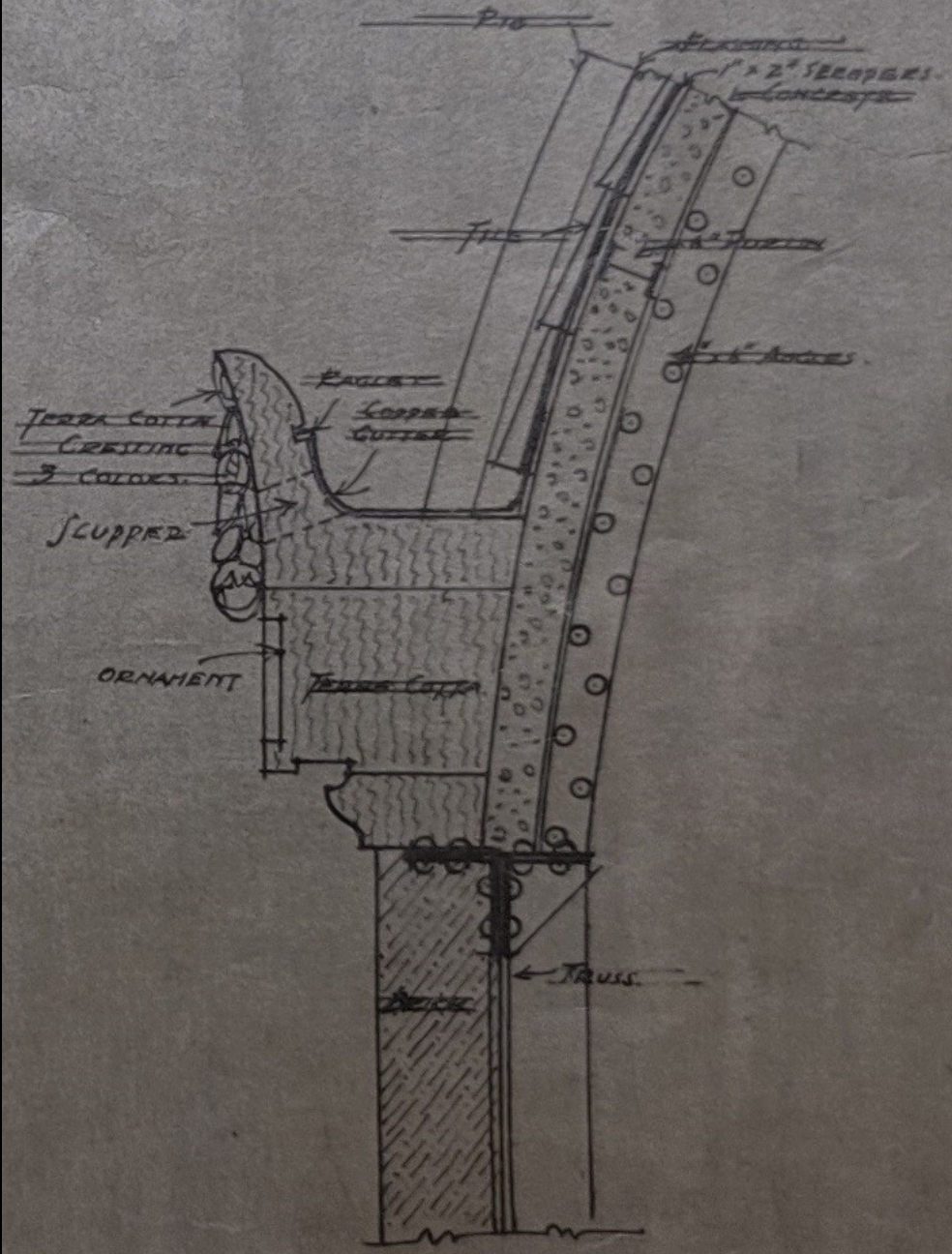
LONGITUDINAL SECTION
RODEF SHOLEM SYNAGOGUE
PITTSBURGH PA.

SCALE 1/4" = 1'-0"

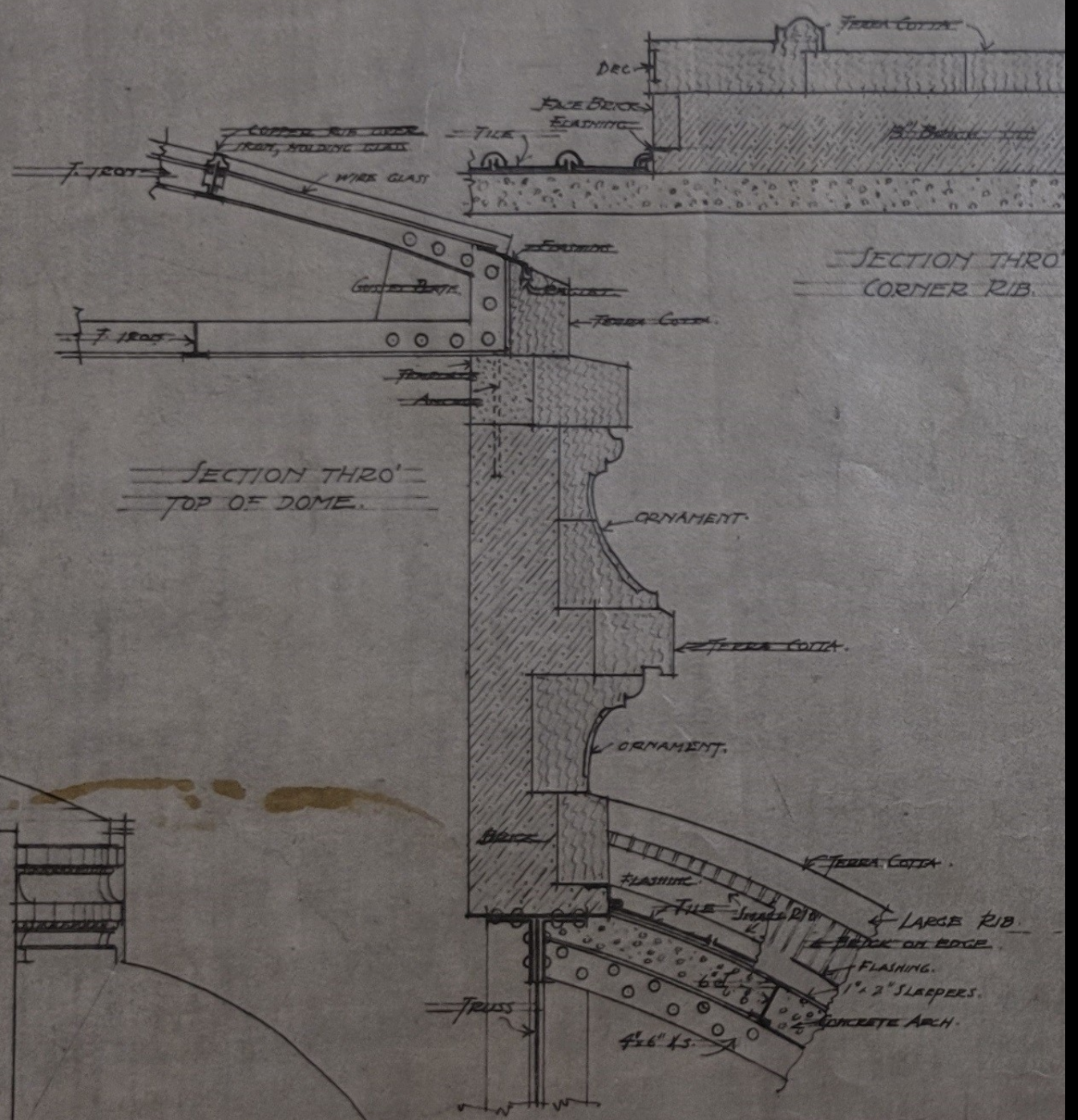
PALMER & HORNBOTEL
ARCHITECTS

DRAWING





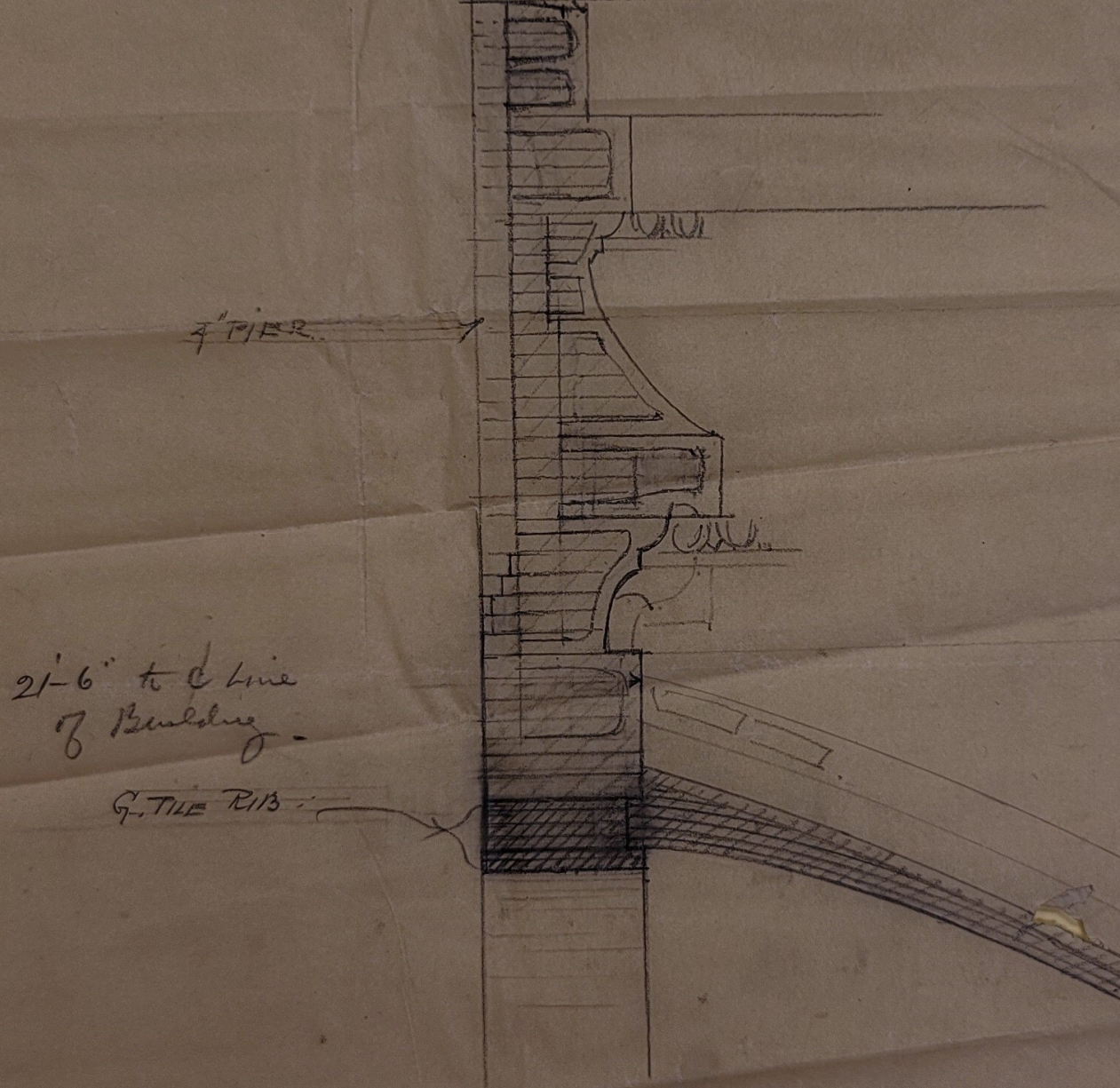
SECTION THRO
TOP OF DRUM.



SECTION THRO
TOP OF DOME.

SECTION THRO
CORNER RIB.

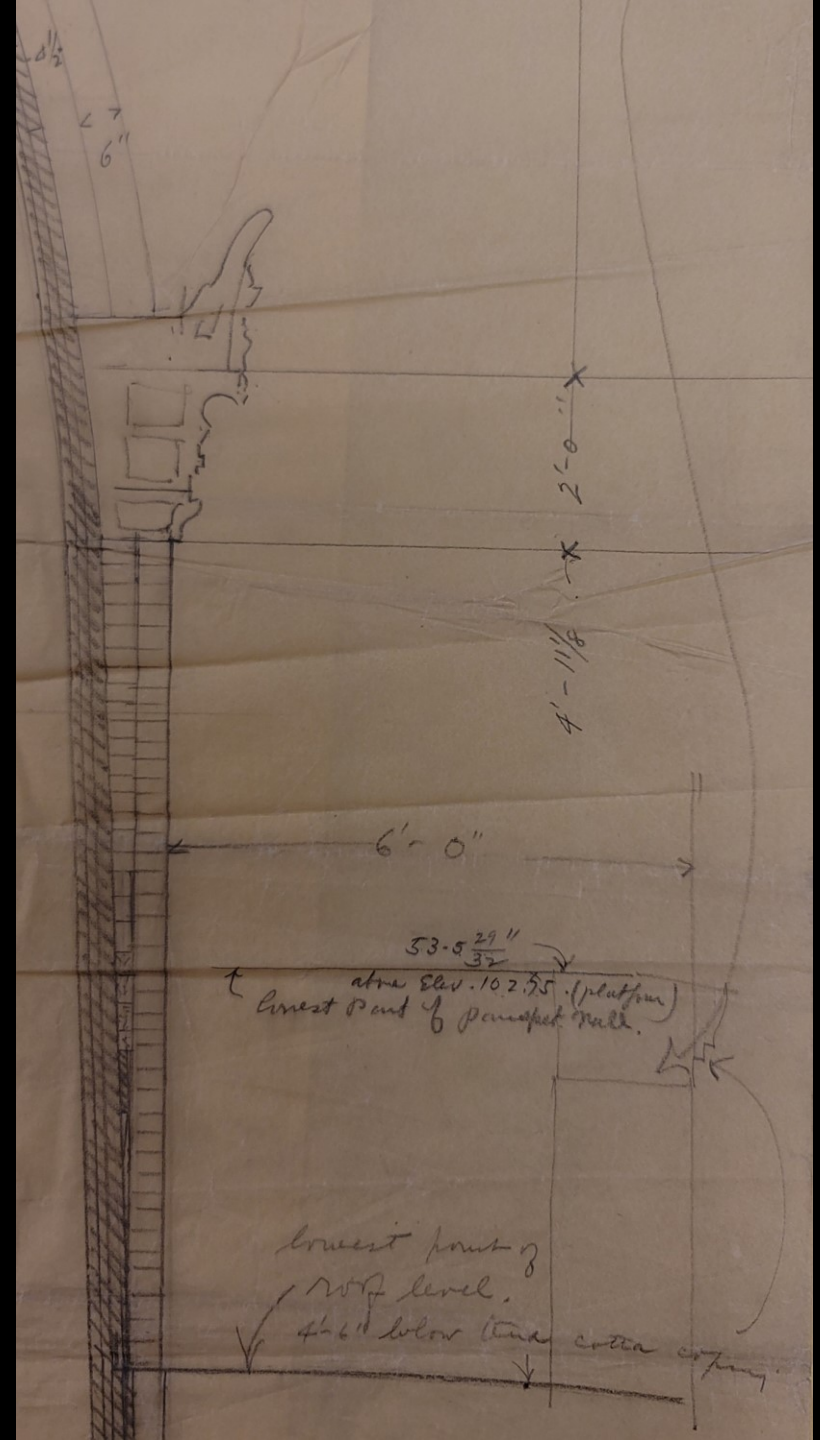
ARCH.



4' FIER

21'-6" to C Line of Building

G-TILE RIB



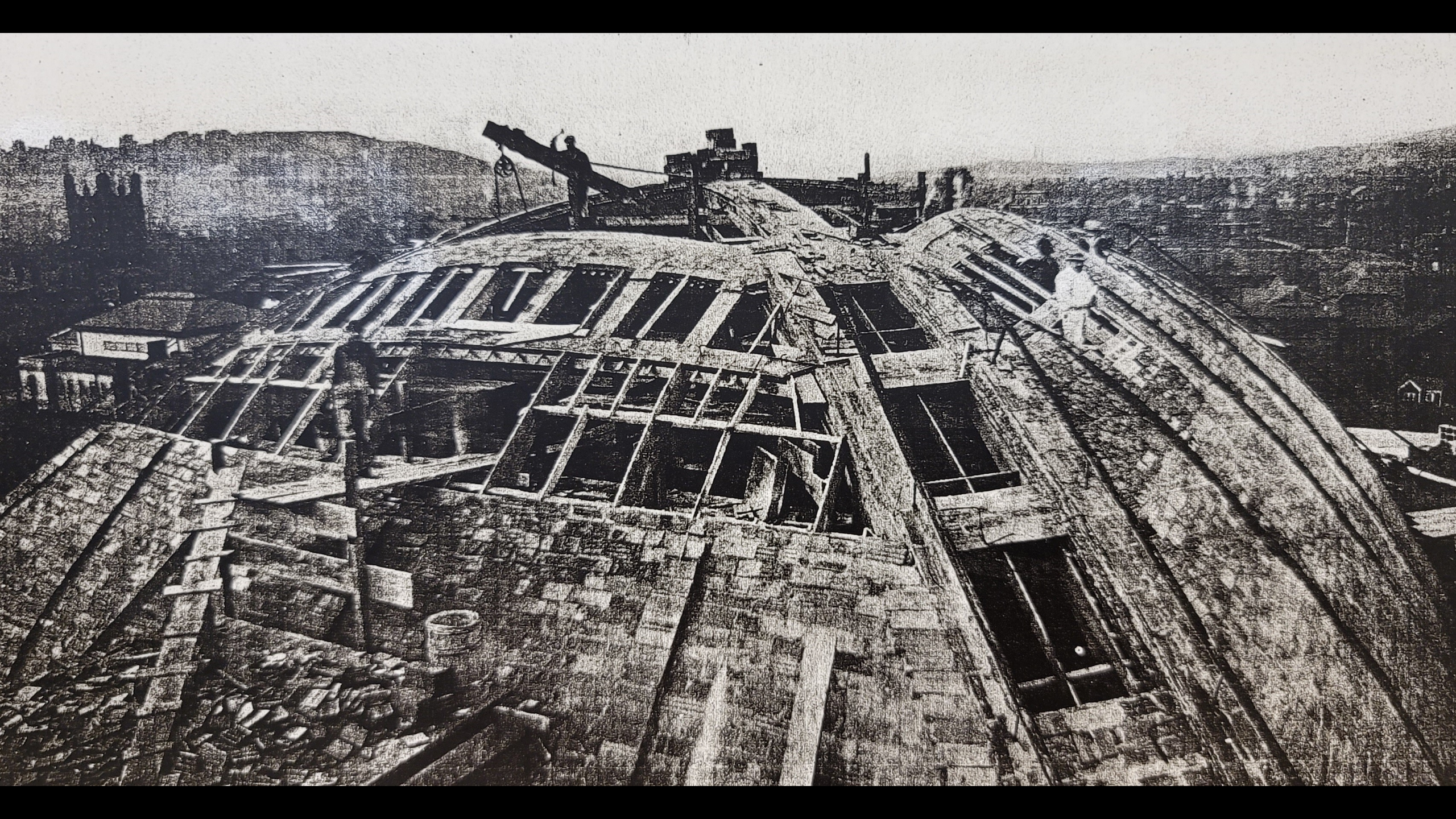
6"

2'-0" X
4'-11/8" X

6'-0"

53-5 ²⁹/₃₂"
above elev. 102.55 (platform)
lowest point of parapet wall.

lowest point of
roof level,
4'-6" below this corner coping

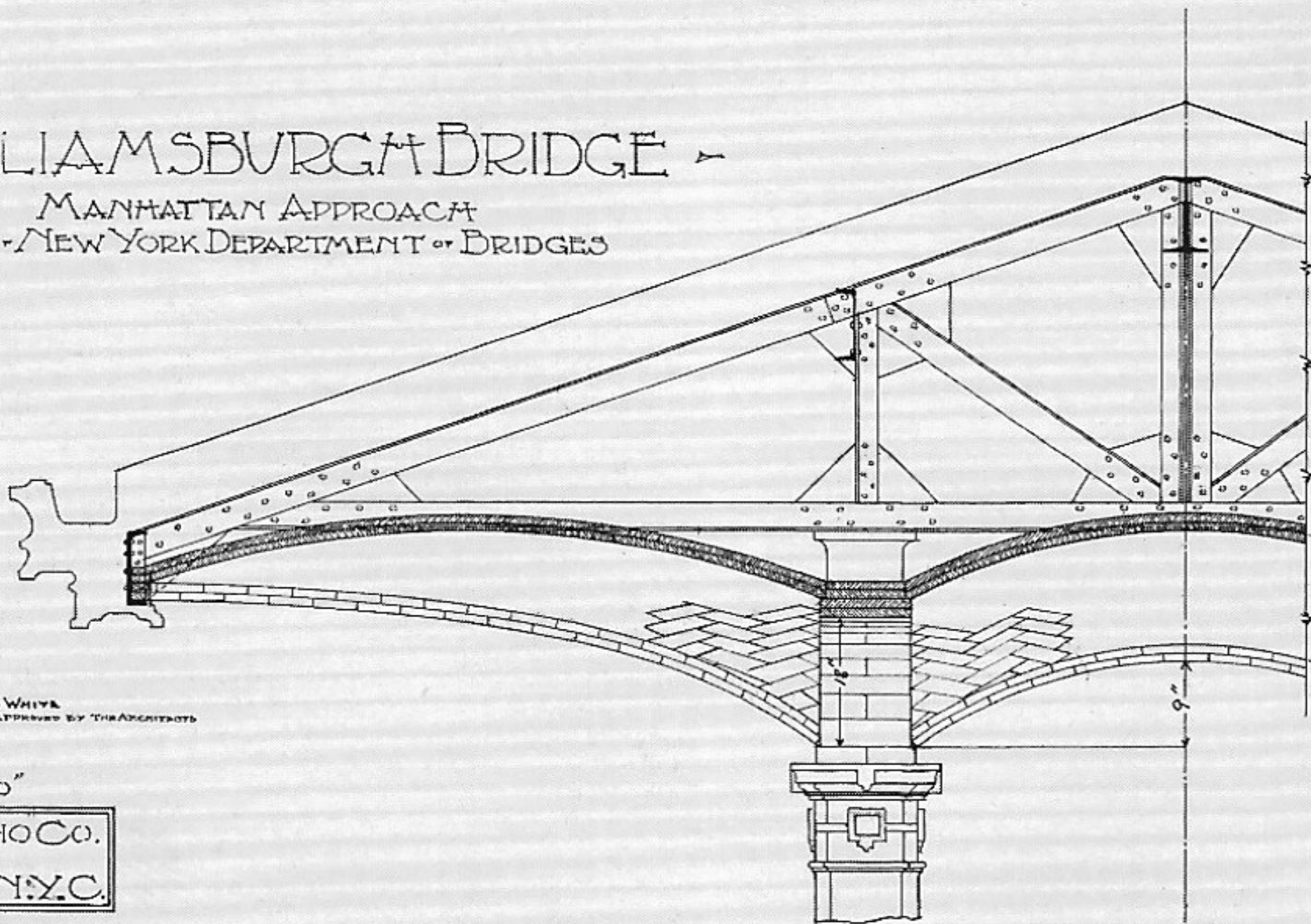






WILLIAMSBURG BRIDGE

MANHATTAN APPROACH
CITY OF NEW YORK DEPARTMENT OF BRIDGES

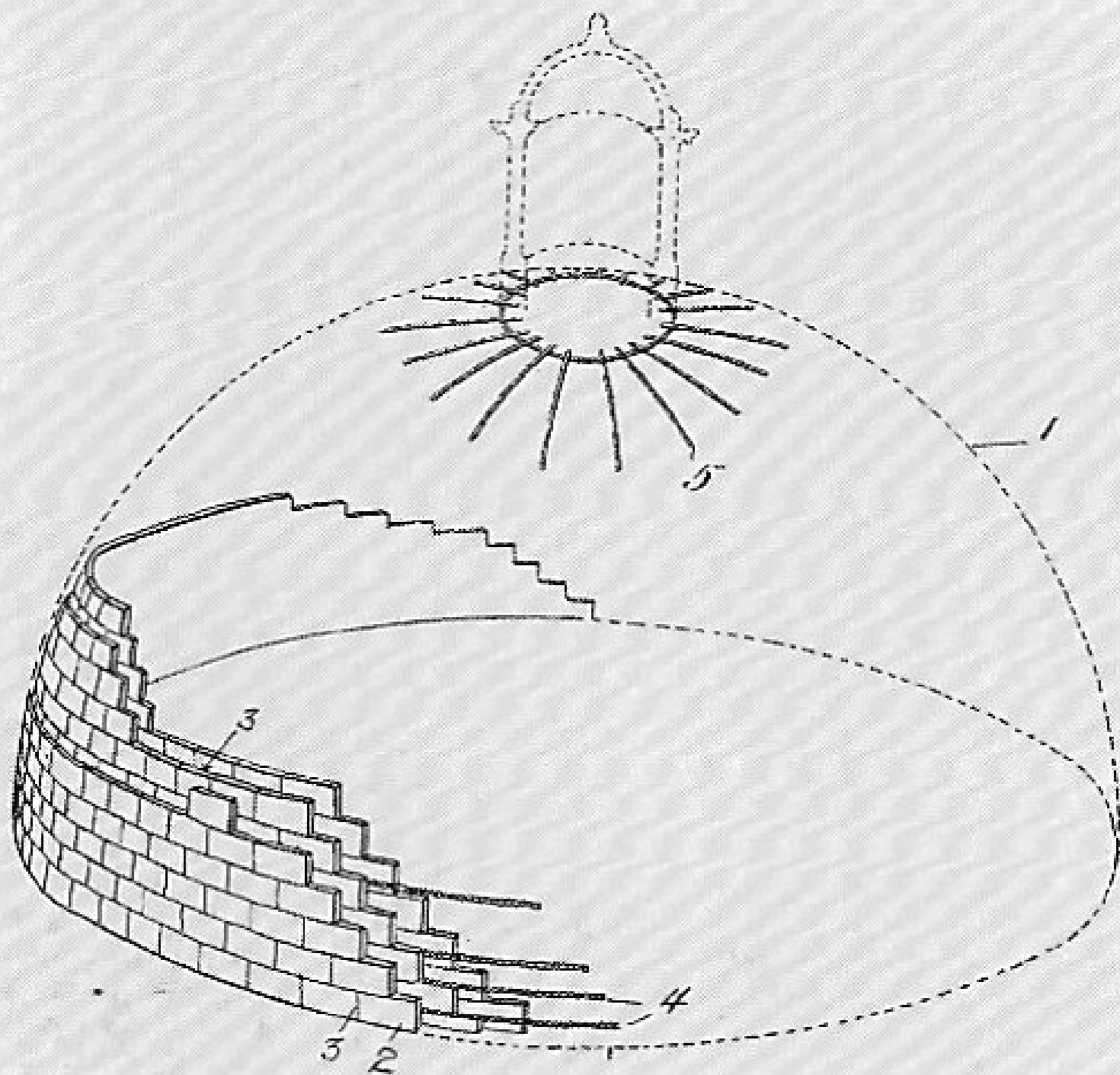


NOTE
CORRUGATED WHITE
GLAZE TILE AS APPROVED BY THE ARCHITECTS

SCALE $\frac{5}{8}'' = 1'-0''$

R. G. GASTAVINO CO.
10. 11. 1907
FULLER BLDG N. Y. C.





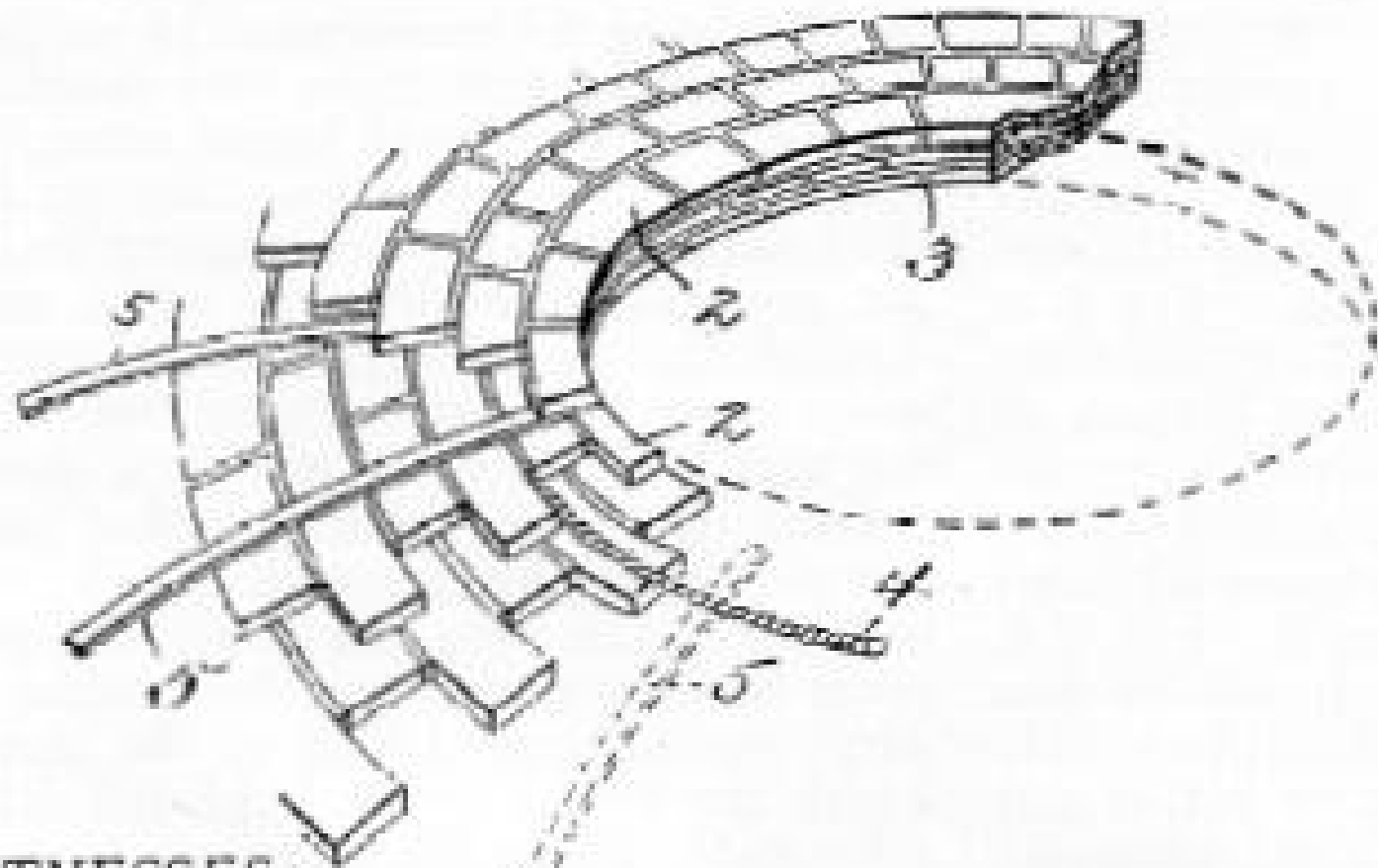


FIG. 2.

WITNESSES.

H. F. Kyle.

A. C. Praddock.

INVENTOR

Rafael Guastavino

BY

Henry M. Brigham
Attorney



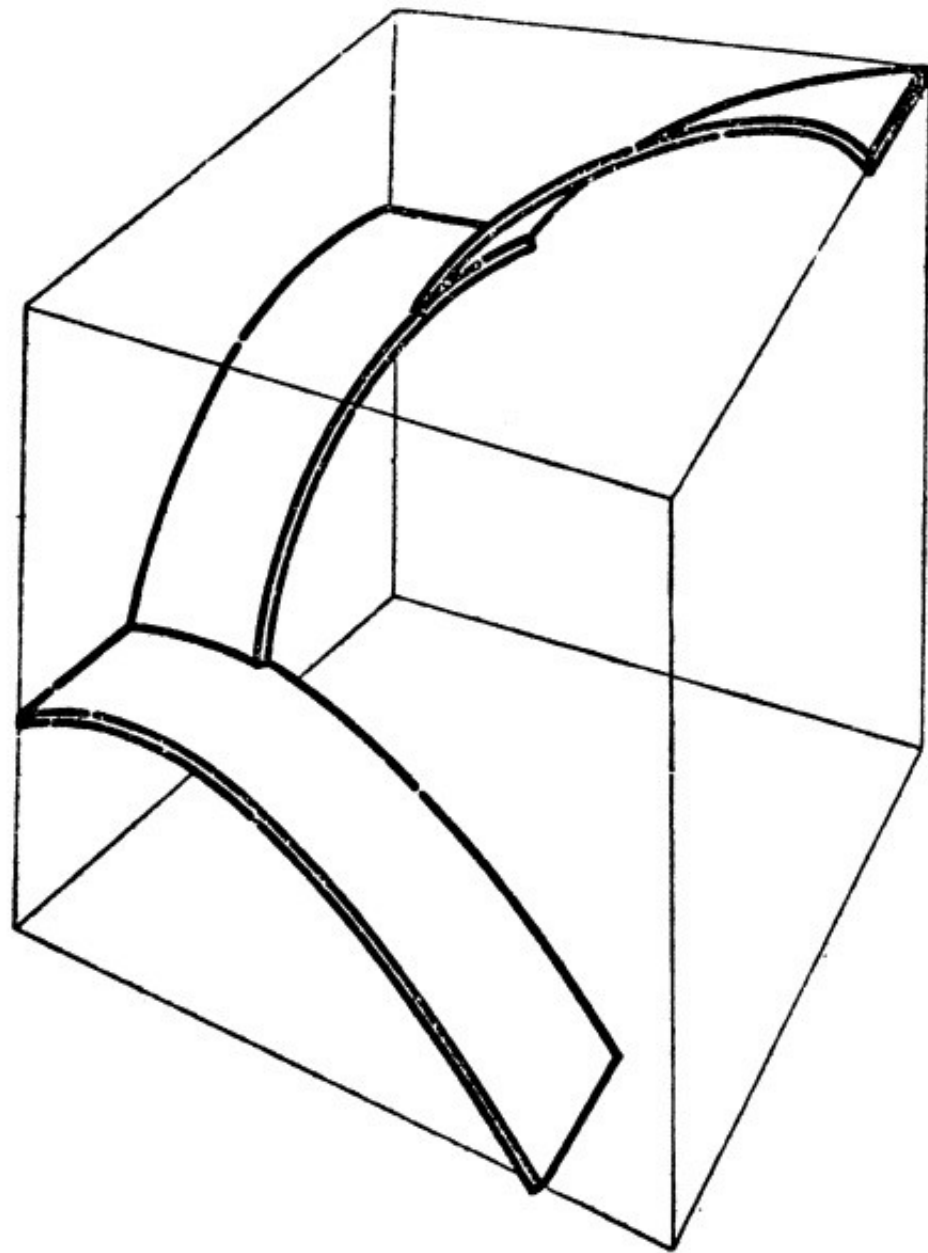


Fig. 21. Diagram of Catalan stair vault that ascends in parabolic stages, each springing from the cantilevered edge of the one below (Casinello, *Bóvedas de ladrillo*).

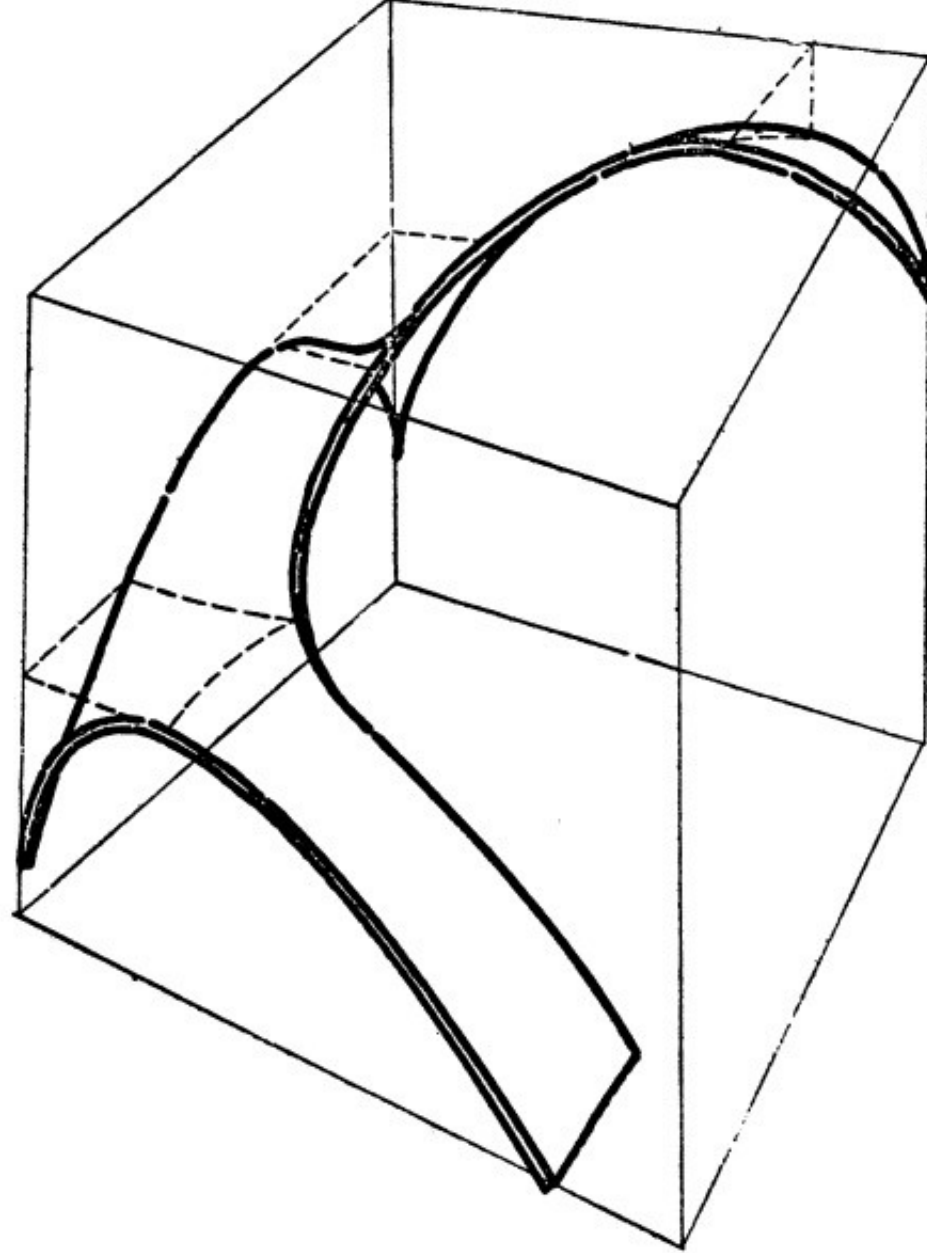
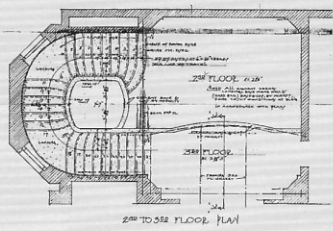
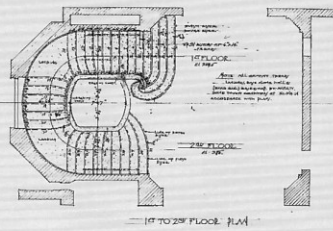
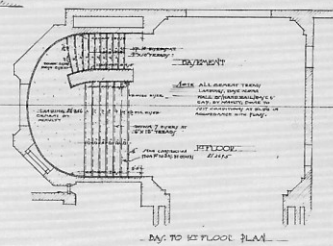
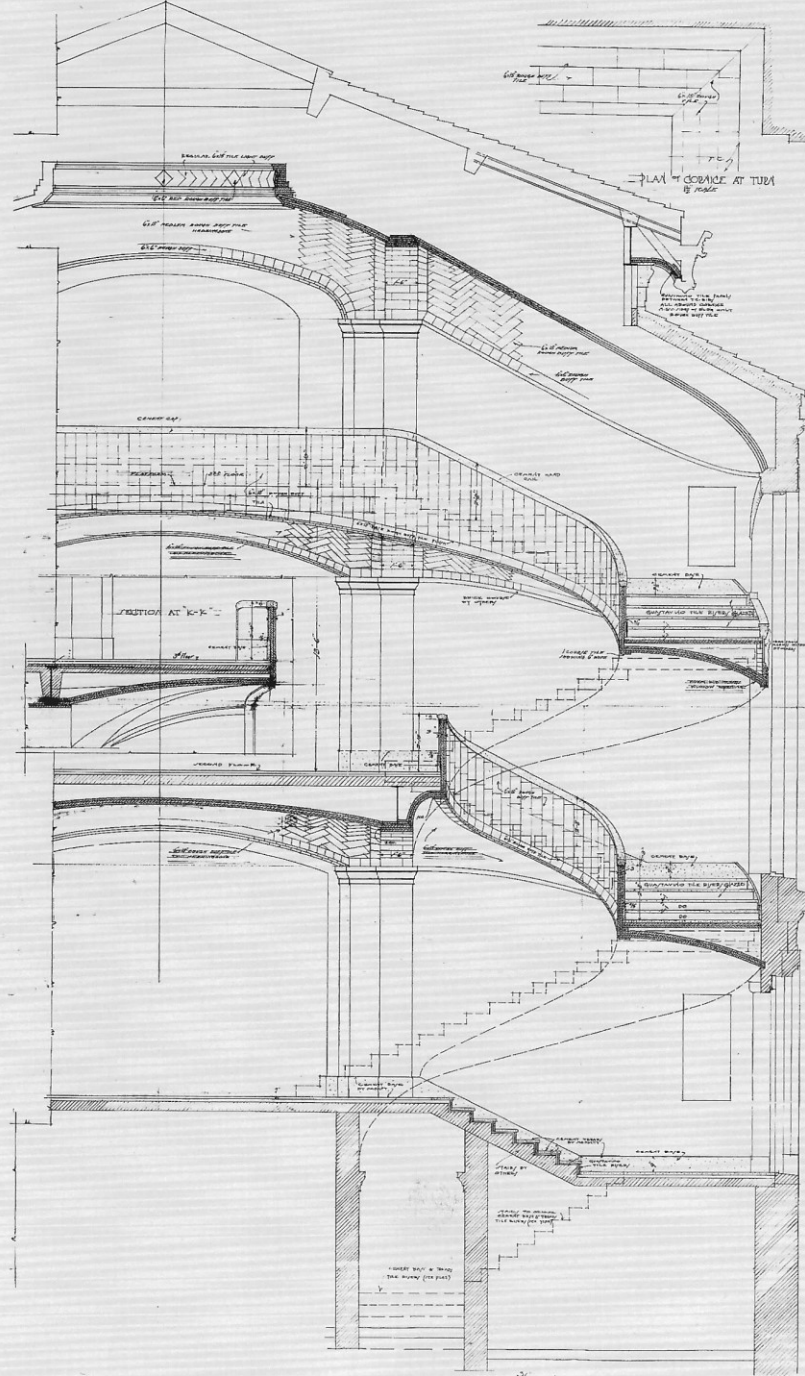


Fig. 22. Diagram of Catalan stair vault with pendentive corners (Casinello, *Bóvedas de ladrillo*).



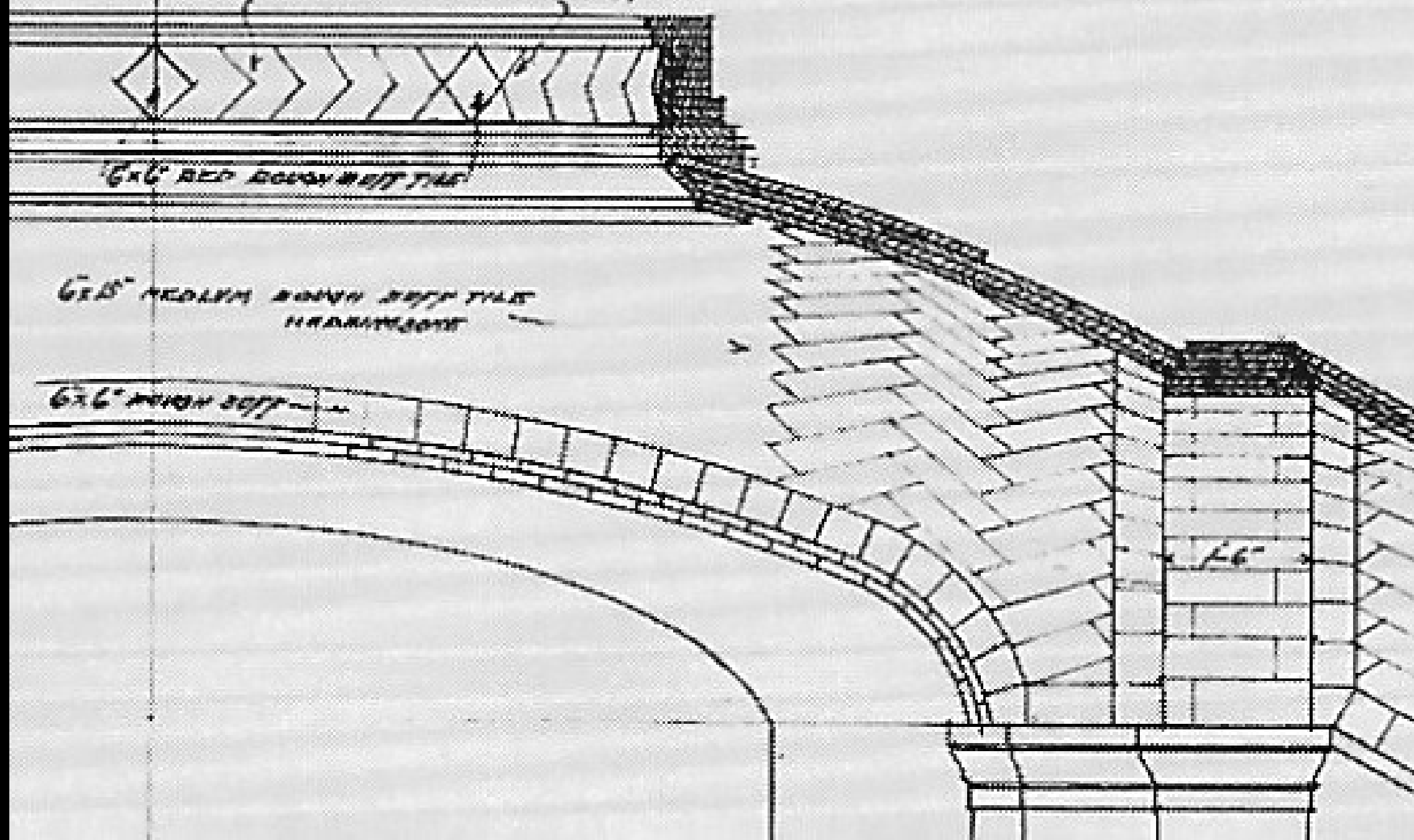


- CENTRAL BUILDING -
 CARNEGIE INSTITUTE OF TECHNOLOGY
 PITTSBURGH PA.
 H. HORNBOETTEL ARCHITECT BLDG. DEPT. C.I.T. PITTS. PA.

1/4" SCALE: CROSS SECTION

| | | | |
|-------------------|---------------|-----------------|----------------|
| DESIGNED BY | HORNBOETTEL | DATE | 1911 |
| DRAWN BY | R. GUASTAVINO | CHECKED BY | H. HORNBOETTEL |
| R. GUASTAVINO CO. | | PITTSBURGH, PA. | |
| CENTRAL BUILDING | | | |

REGULAR 6x8 TILE LIGHT CUFF

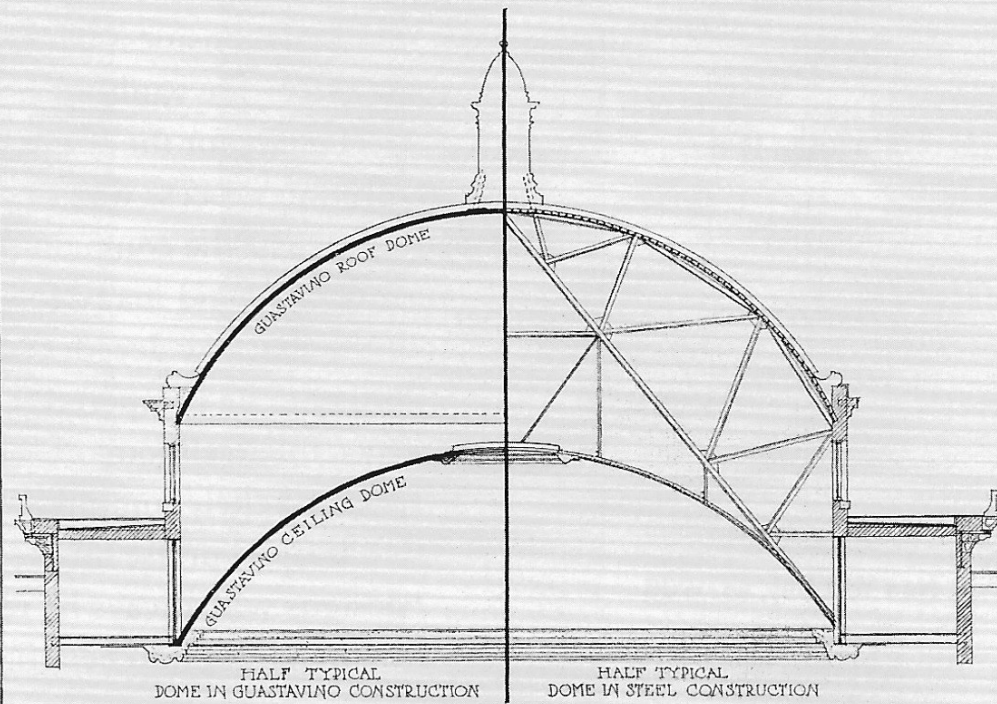


6x6 RED ROUGH SET TILE

6x8" RED LUMBER BROWN SET TILE HEADINGS

6x6" ROUGH SET

46"



GUASTAVINO CONSTRUCTION *vs.* STEEL FOR DOMES

STEEL FRAME CONSTRUCTION FOR DOMES IS COMPLICATED (SEE DRAWING), EXPENSIVE AND SUBJECT TO ANNOYING AND COSTLY DELAYS IN DELIVERY.

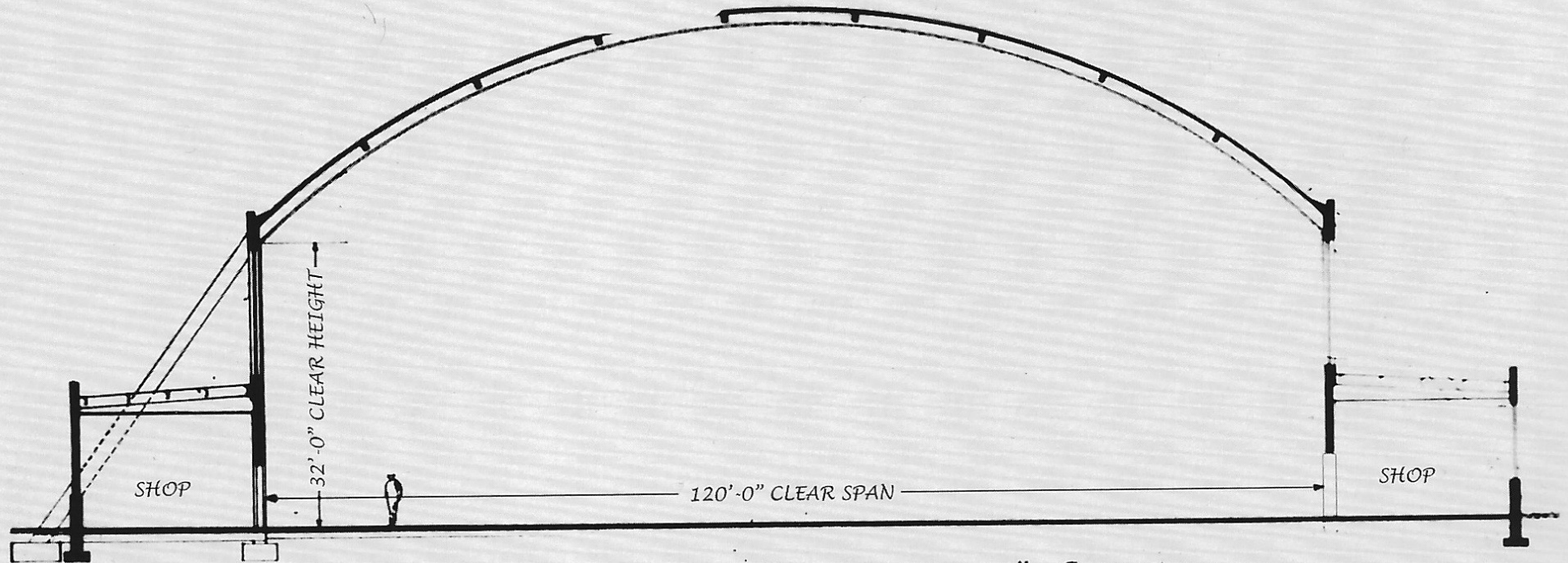
GUASTAVINO CONSTRUCTION IS SIMPLE (SEE DRAWING), IS ECONOMICAL AND THE NECESSARY MATERIALS CAN ALWAYS BE DELIVERED PROMPTLY.

LET US SHOW HOW OUR SYSTEM CAN BE APPLIED TO THE PROBLEMS NOW IN YOUR OFFICE. SEND US YOUR DRAWINGS FOR SUGGESTIONS.

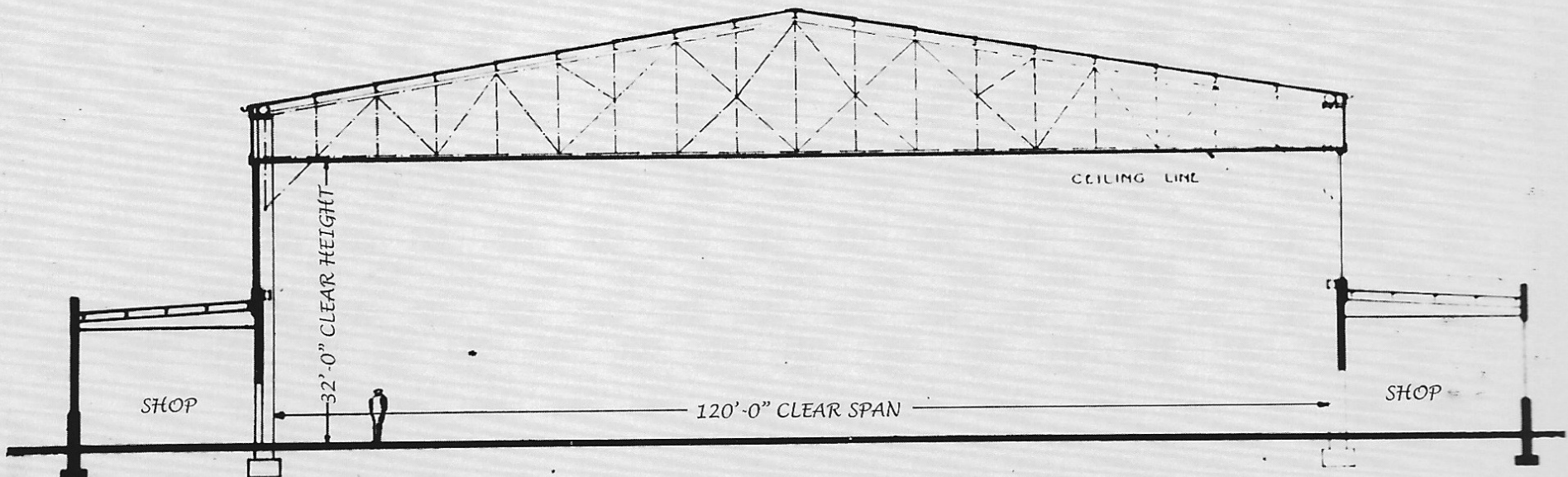
R. GUASTAVINO CO.

40 Court Street
Boston, Mass.

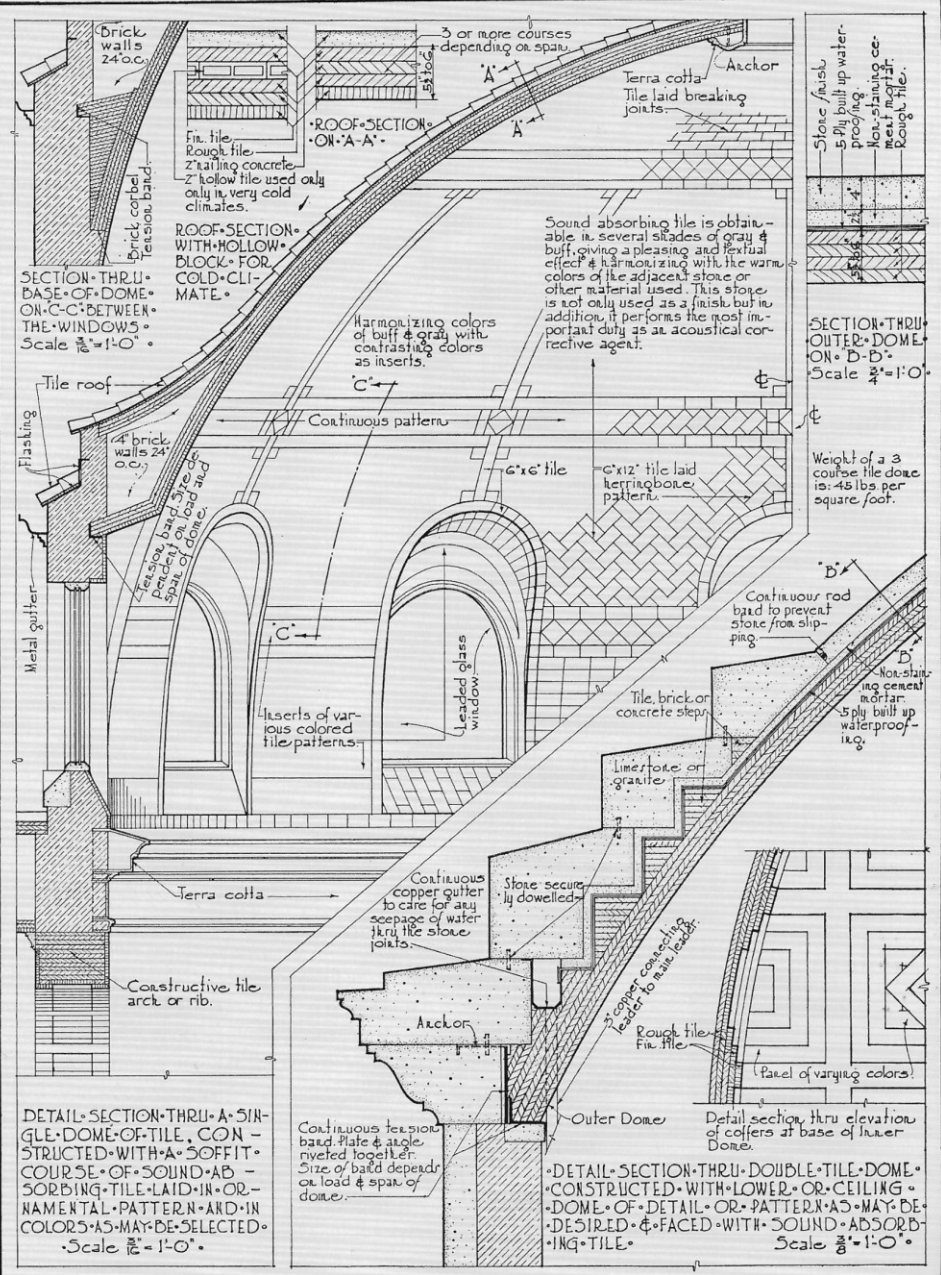
Fuller Building
New York

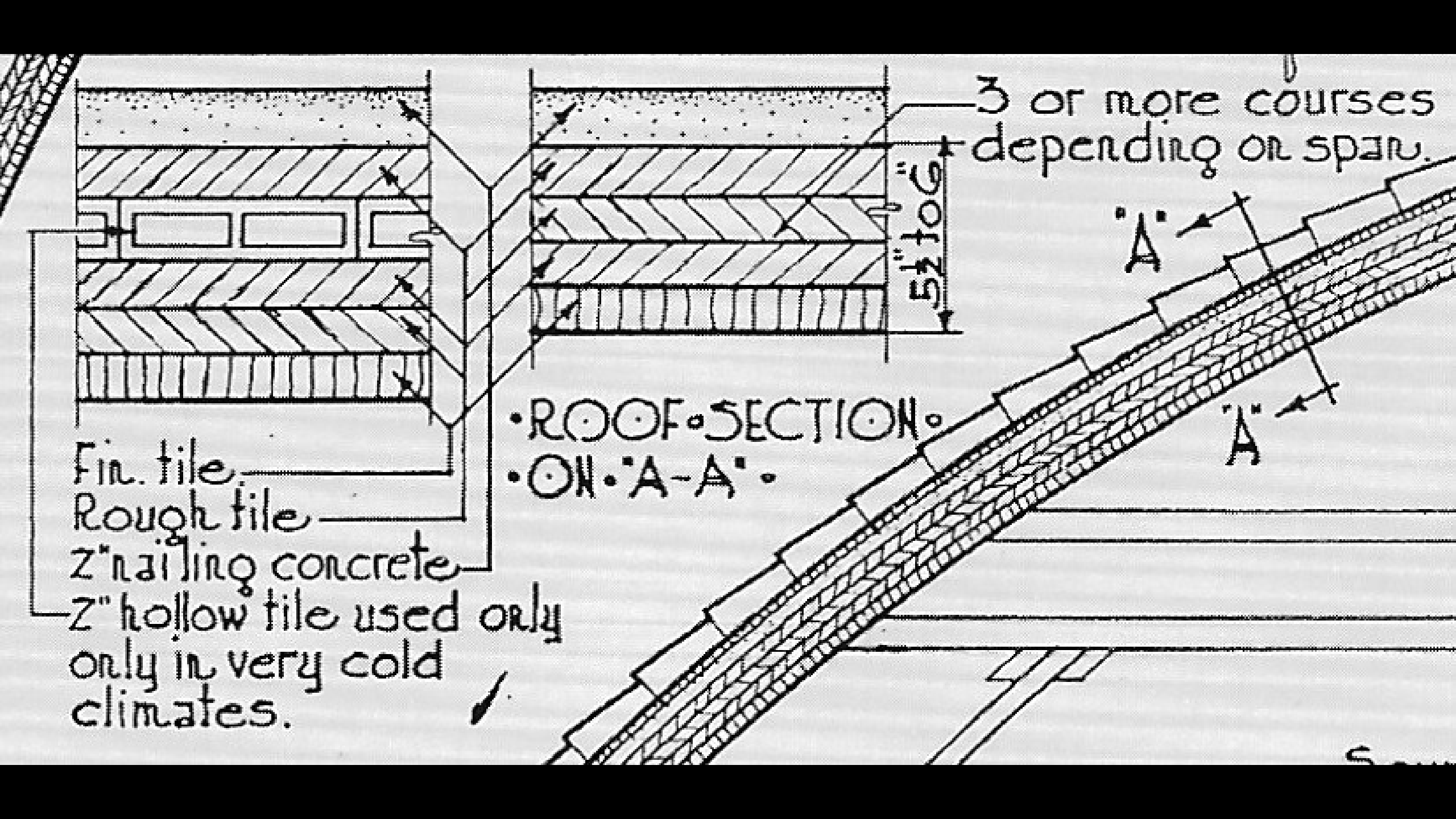


TYPICAL SECTION THROUGH "GUASTAVINO" CONSTRUCTION



TYPICAL SECTION THROUGH TRUSS & CEILING CONSTRUCTION



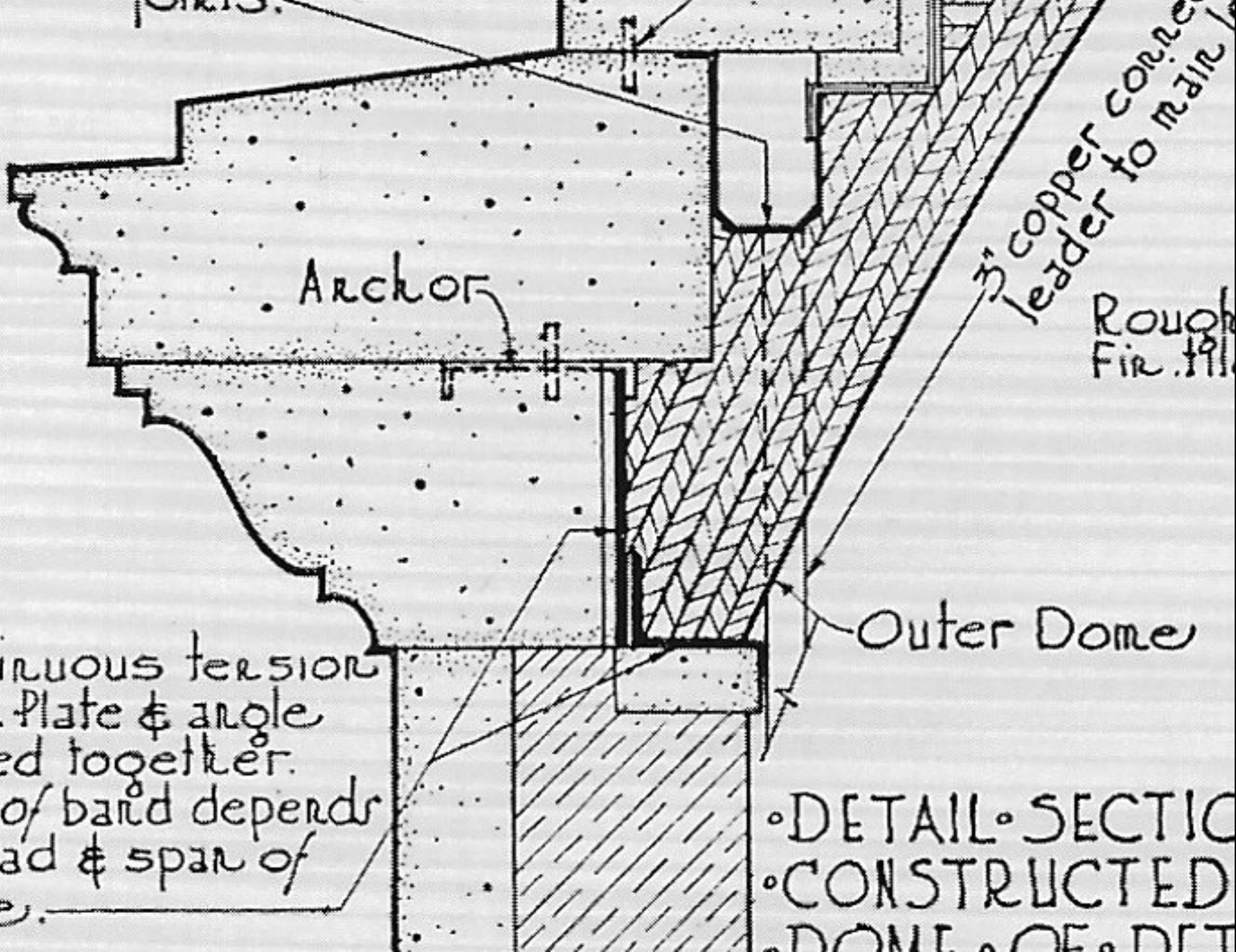


3 or more courses depending on span.

5 1/2" TOG

• ROOF SECTION •
 • ON 'A-A' •

Fin. tile
 Rough tile
 2" nailing concrete
 2" hollow tile used only
 only in very cold
 climates.



ARCH OF

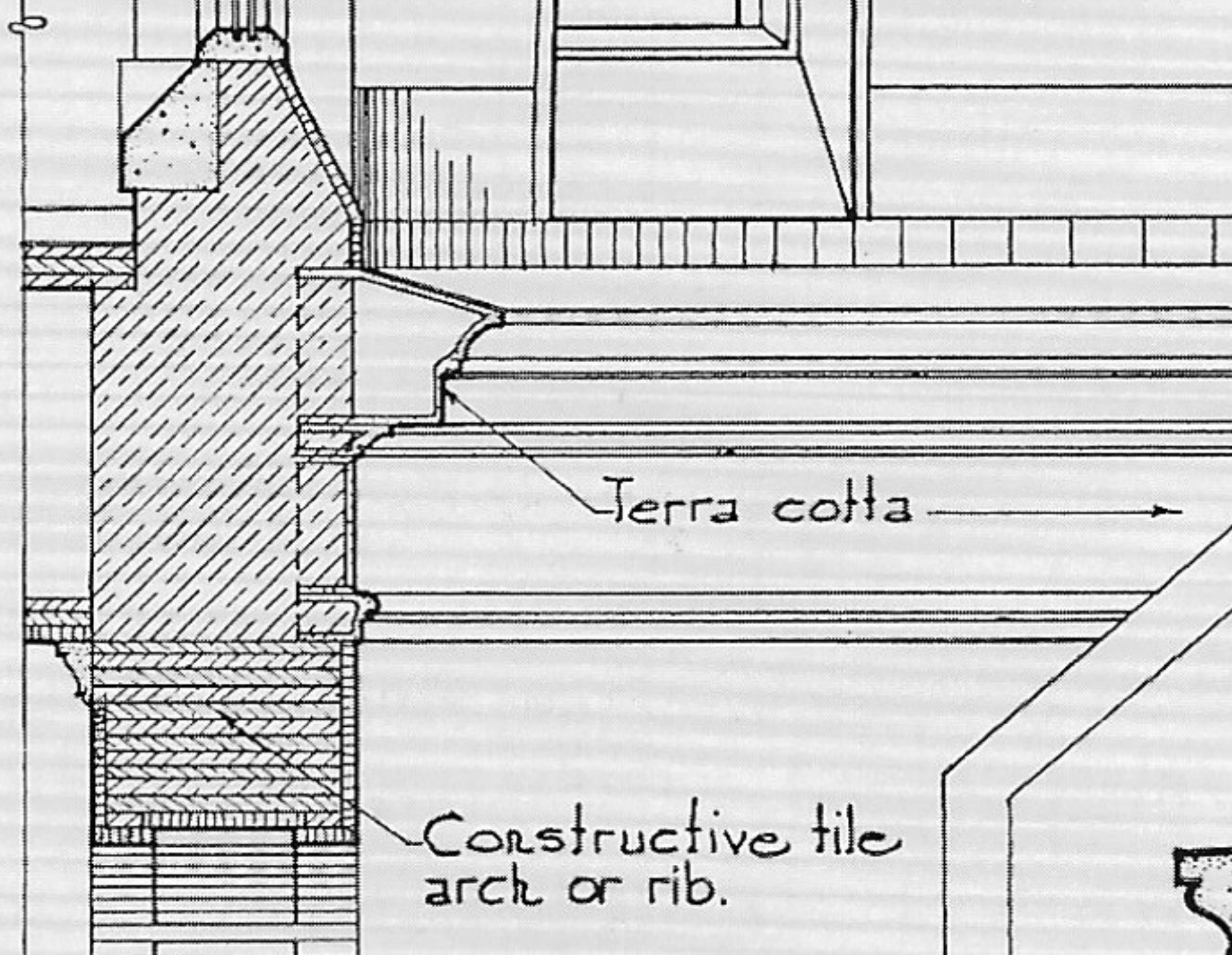
3" copper cornice
leader to main

Rough
Fir

Outer Dome

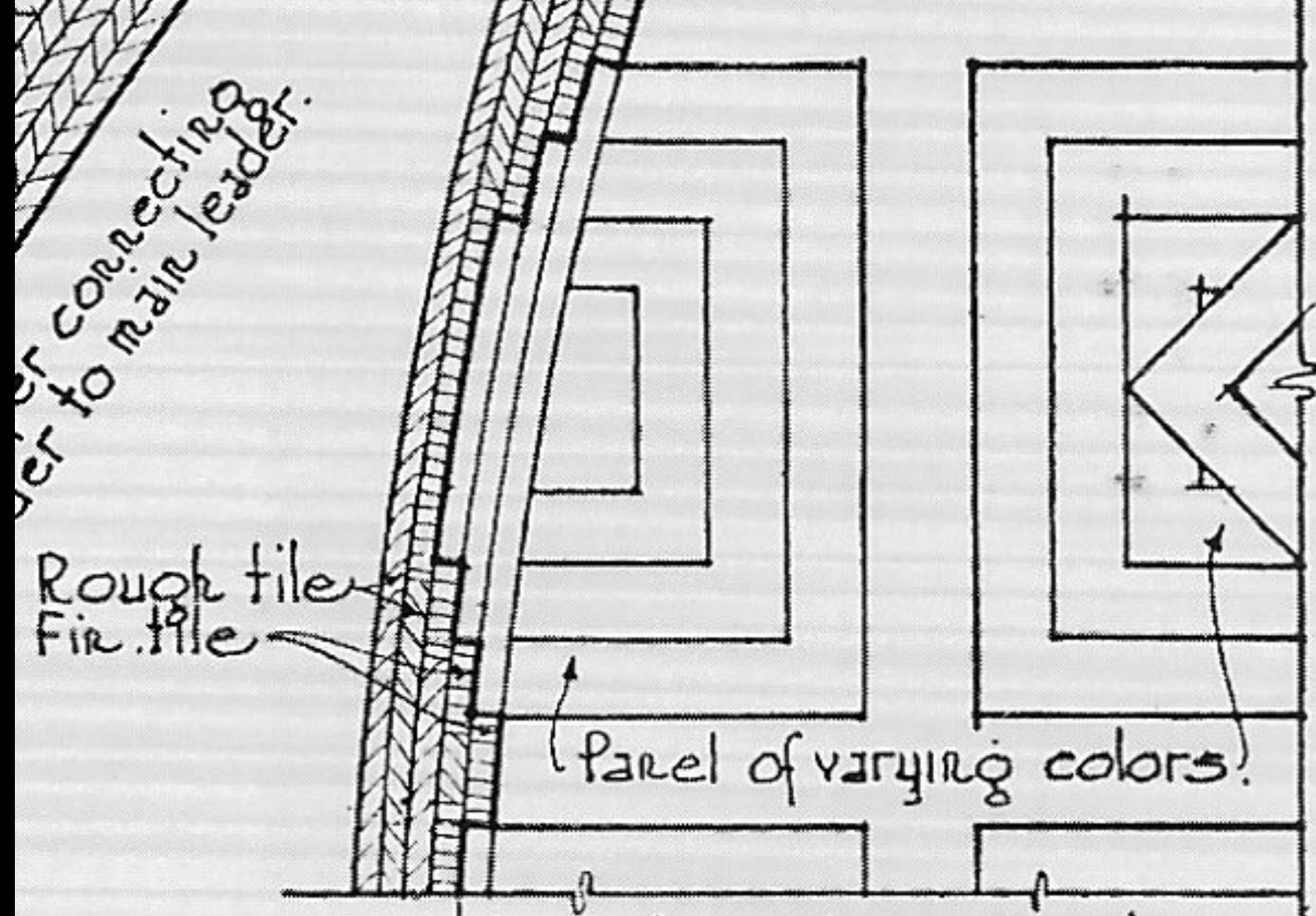
Continuous tension
band. Plate & angle
riveted together.
Size of band depends
on load & span of
dome.

DETAIL SECTION
CONSTRUCTED
DOME OF DET



Terra cotta

Constructive tile arch or rib.



Sound absorbing tile is obtainable in several shades of gray & buff, giving a pleasing and textural effect & harmonizing with the warm colors of the adjacent stone or other material used. This stone is not only used as a finish but in addition it performs the most important duty as an acoustical corrective agent.

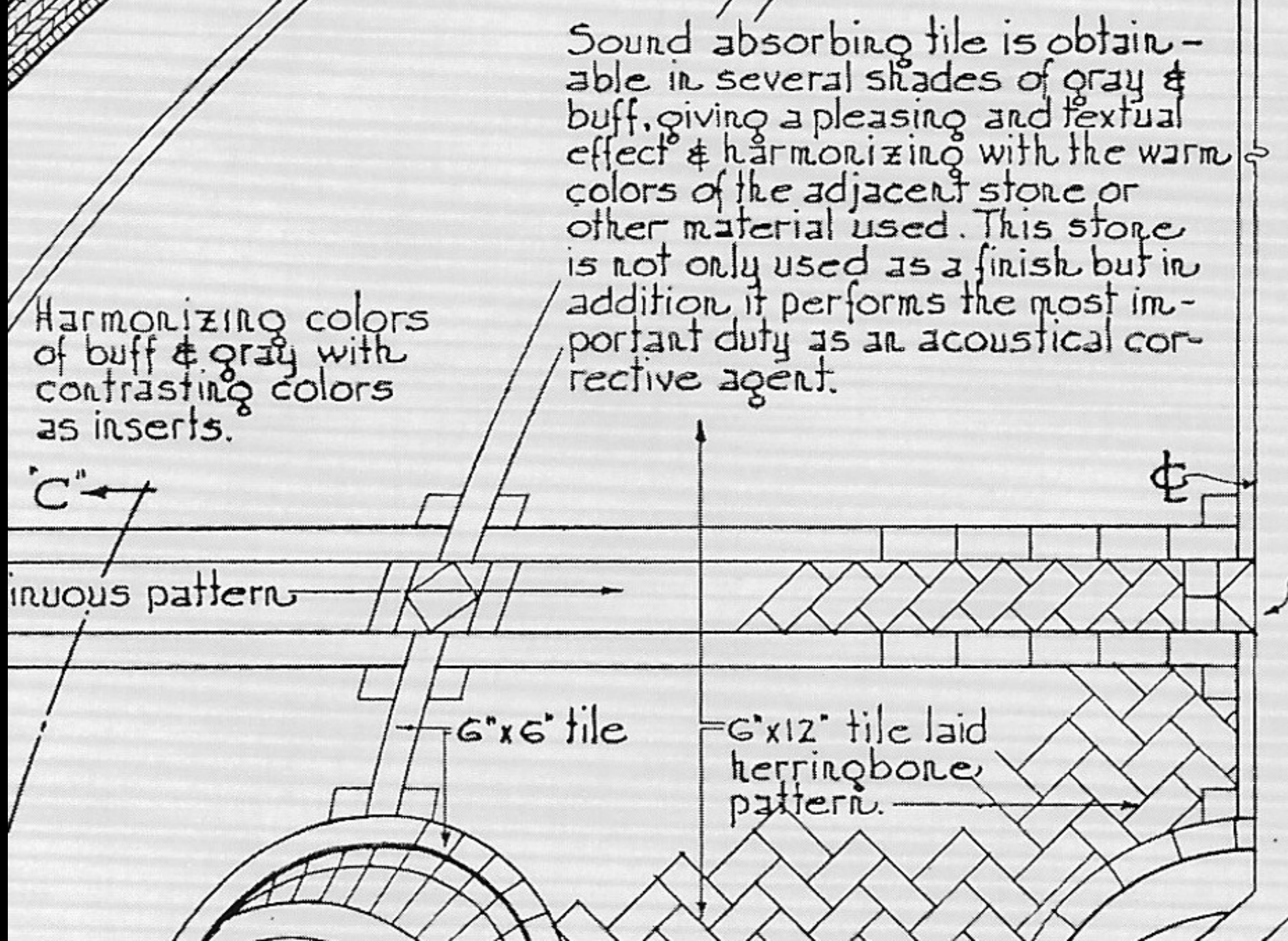
Harmonizing colors of buff & gray with contrasting colors as inserts.

C" ←

continuous pattern

6" x 6" tile

6" x 12" tile laid herringbone pattern.









Whitfield
temporarily closed

e Hotel Pittsburgh
Temporarily closed

Mignonette St

S Whitfield St

Level 0

East Liberty
Presbyterian Church

Baum Square

5940

East Liberty
Fountain

Lincoln Hwy

USPS Drop Box

Google

S Highland Ave

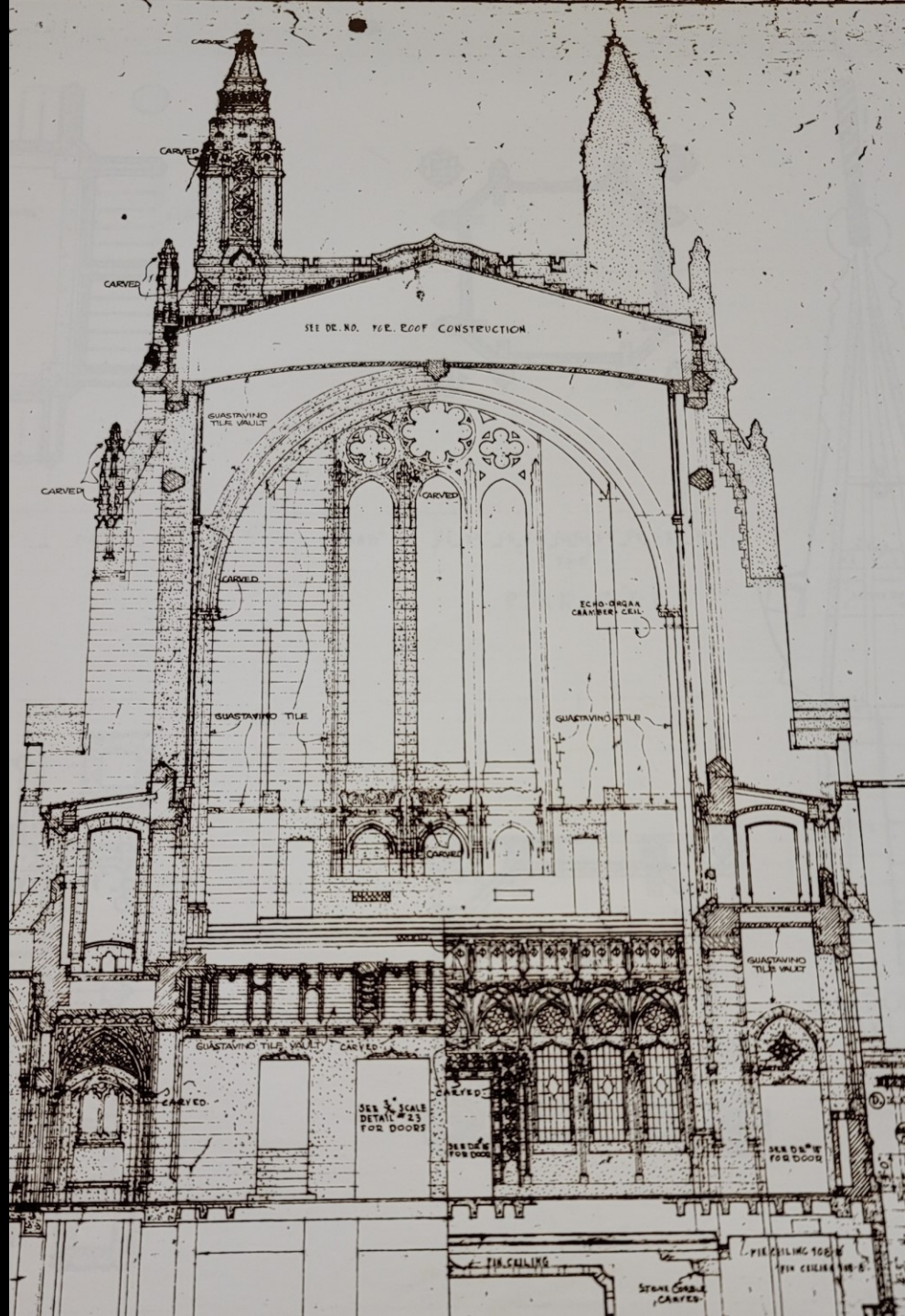
S Highland Ave

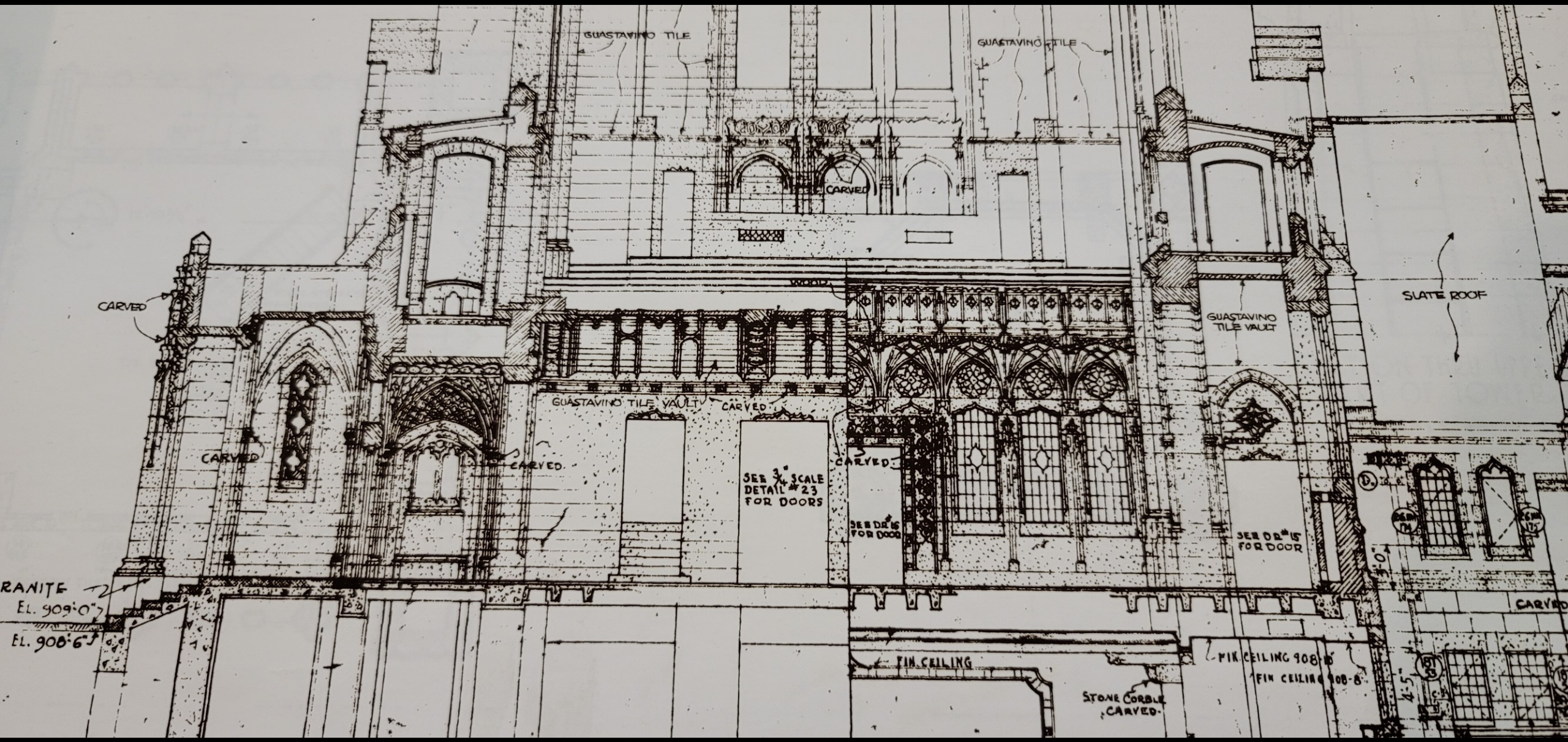
121

111

604

Per





GUASTAVINO TILE

GUASTAVINO TILE

SLATE ROOF

GUASTAVINO TILE VAULT

GUASTAVINO TILE VAULT CARVED

SEE SCALE DETAIL # 23 FOR DOORS

SEE DR # 15 FOR DOOR

SEE DR # 15 FOR DOOR

GRANITE EL. 909'-0"

EL. 908'-6"

FIN. CEILING

FIN. CEILING 908'-0"
FIN. CEILING 908'-6"

STONE CORBLE CARVED

CARVED

CARVED

CARVED

CARVED

CARVED

(D)

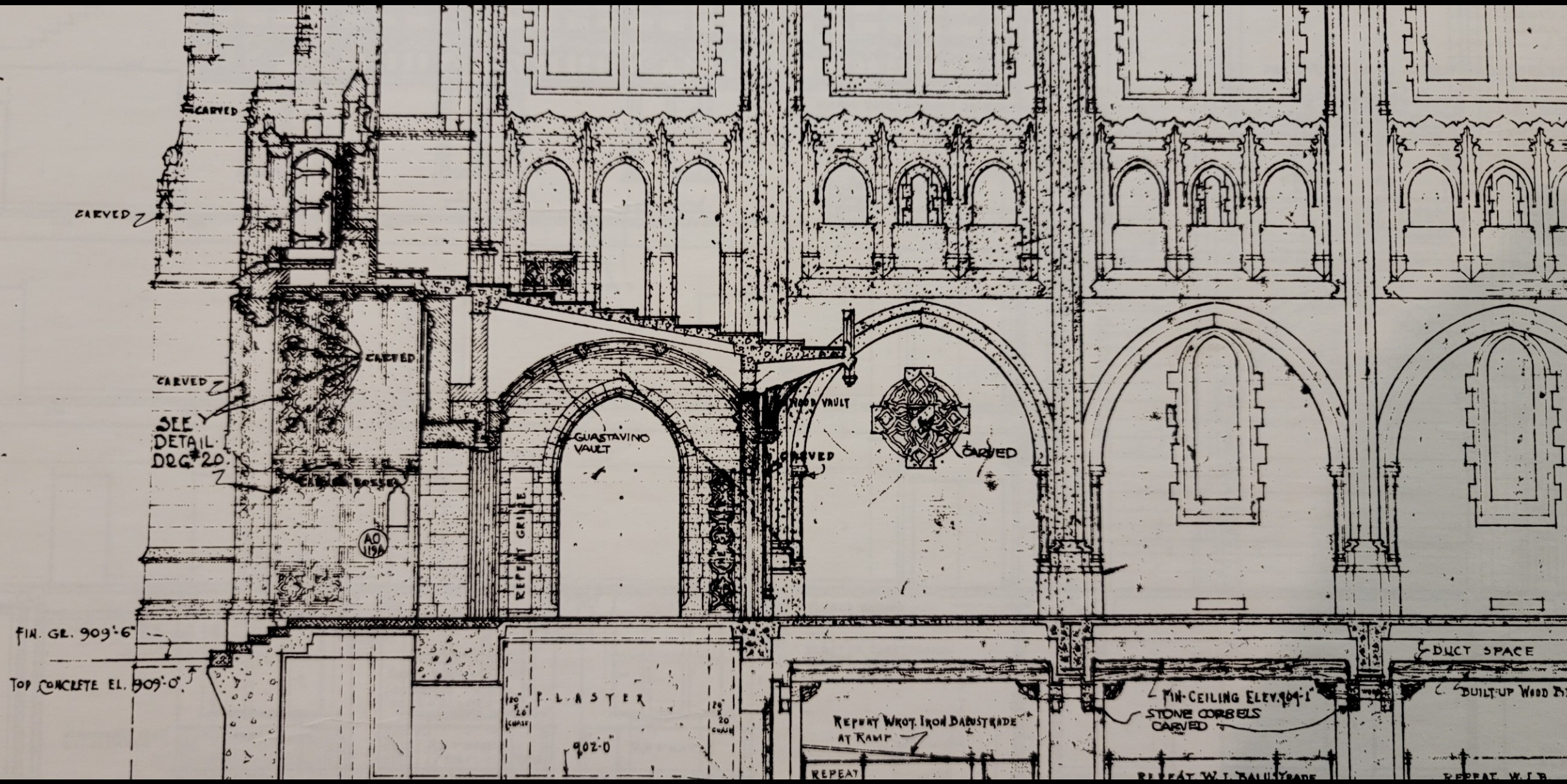
(E)

(F)

(G)

(H)

4'-5"



CARVED

CARVED

CARVED

SEE
DETAIL
DRG. 20

CARVED

GUASTAVINO
VAULT

WOOD VAULT

CARVED

CARVED

FIN. GL. 909'-6"

TOP CONCRETE EL. 909'-0"

PLASTER

902'-0"

REPEAT WROT. IRON BALUSTRADE
AT RAMP

REPEAT

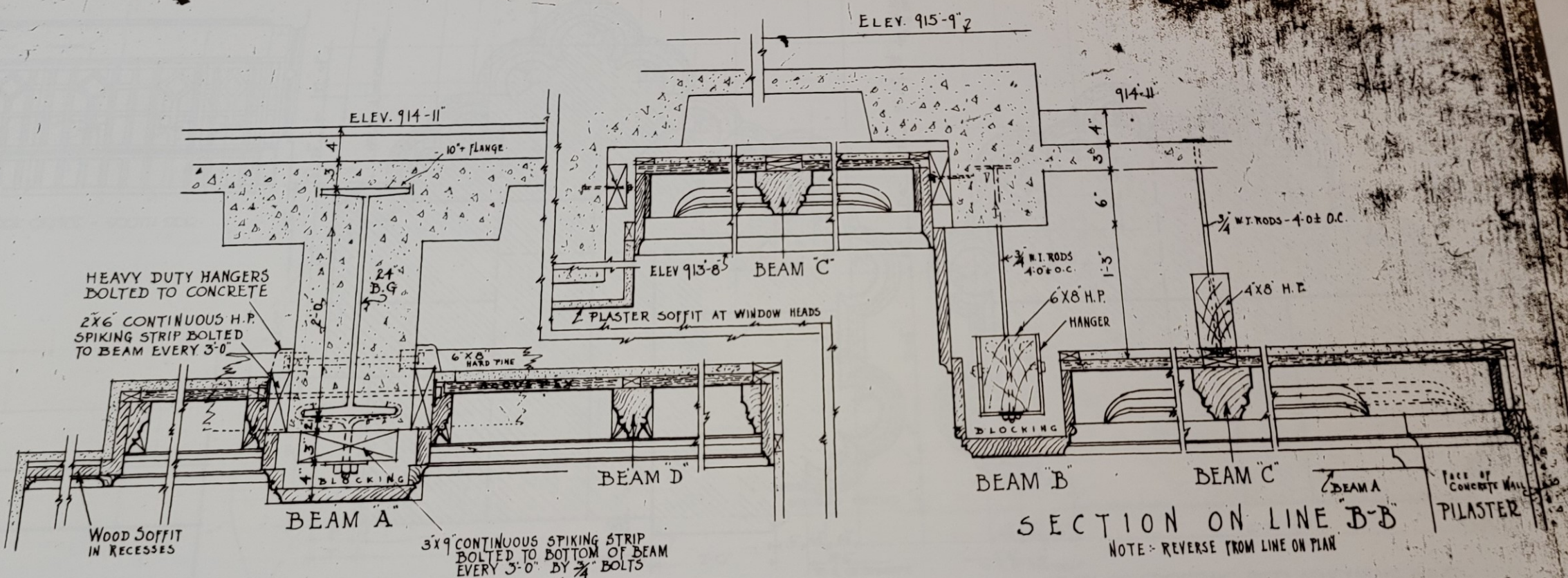
FIN. CEILING ELEV. 909'-1"
STONE CORBELS
CARVED

REPEAT W.I. BALUSTRADE

DUCT SPACE

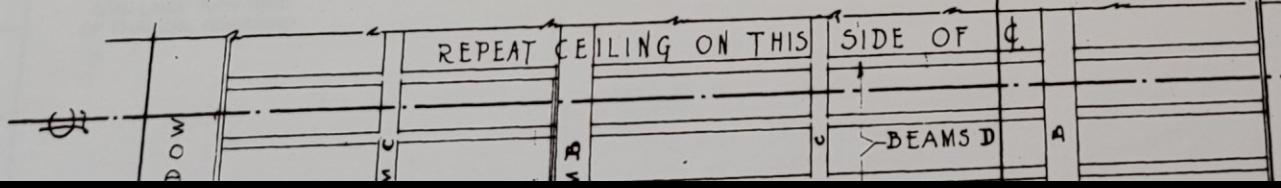
BUILT-UP WOOD BE.

REPEAT W.I.B.



SECTION ON LINE "A-A"

SECTION ON LINE "B-B"
NOTE: REVERSE FROM LINE ON PLAN



DETAILS FOR CAFETERIA CEILING
SCALE 1/2" = 1'-0"



CARVED

CARVED

SEE DR. NO. FOR ROOF CONSTRUCTION

GUASTAVINO
TILE VAULT

CARVED

CARVED

CARVED























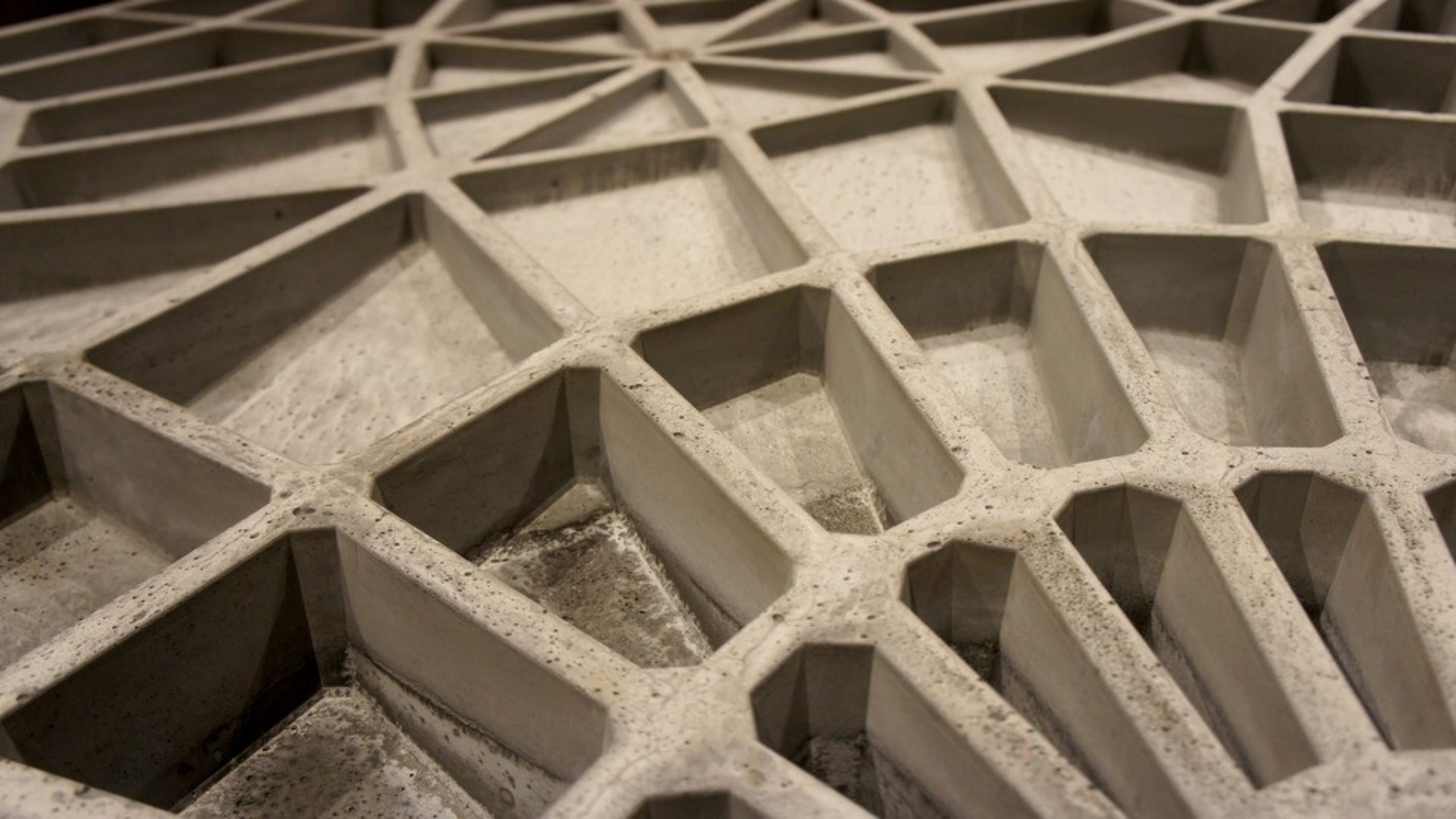




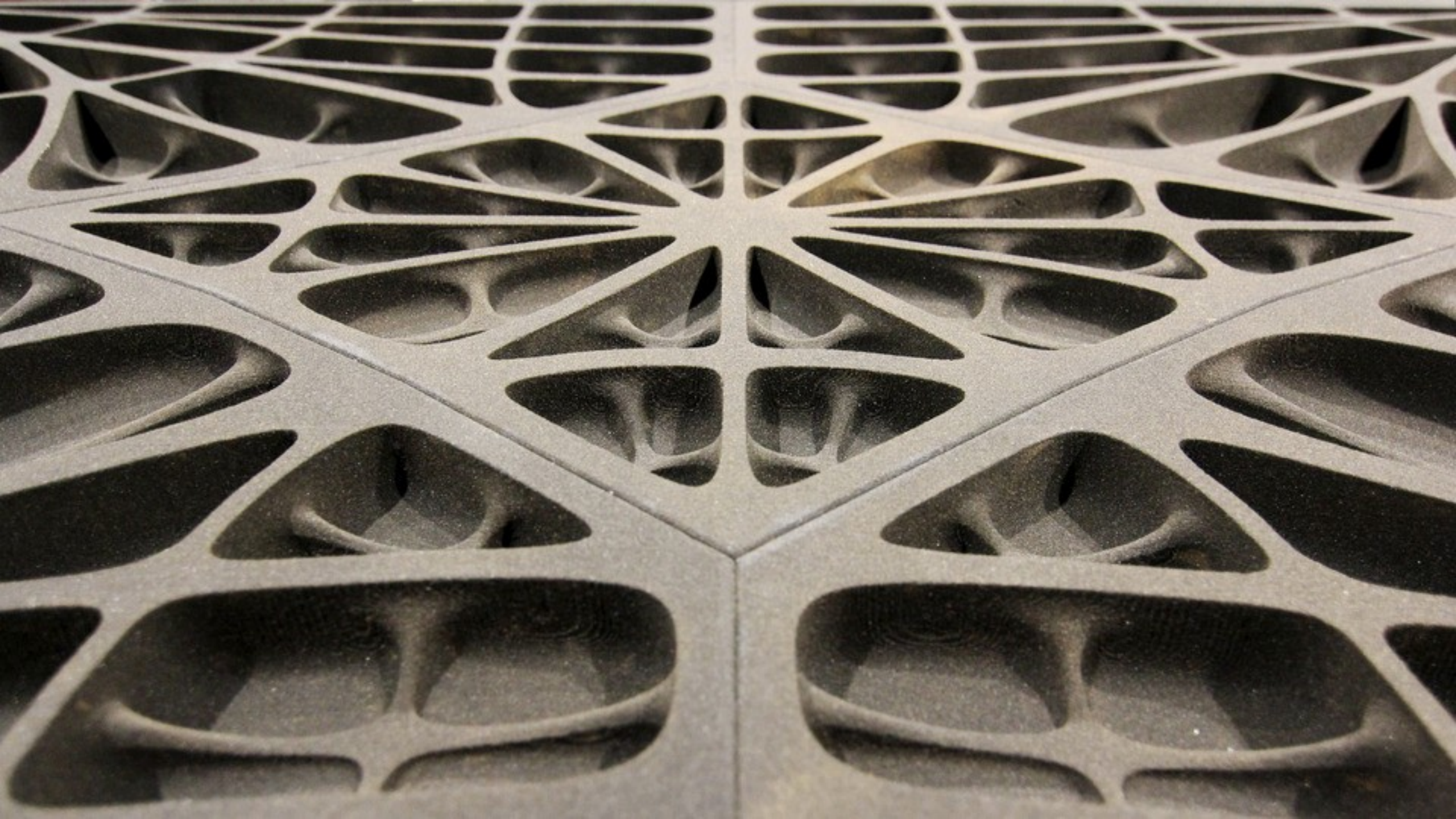










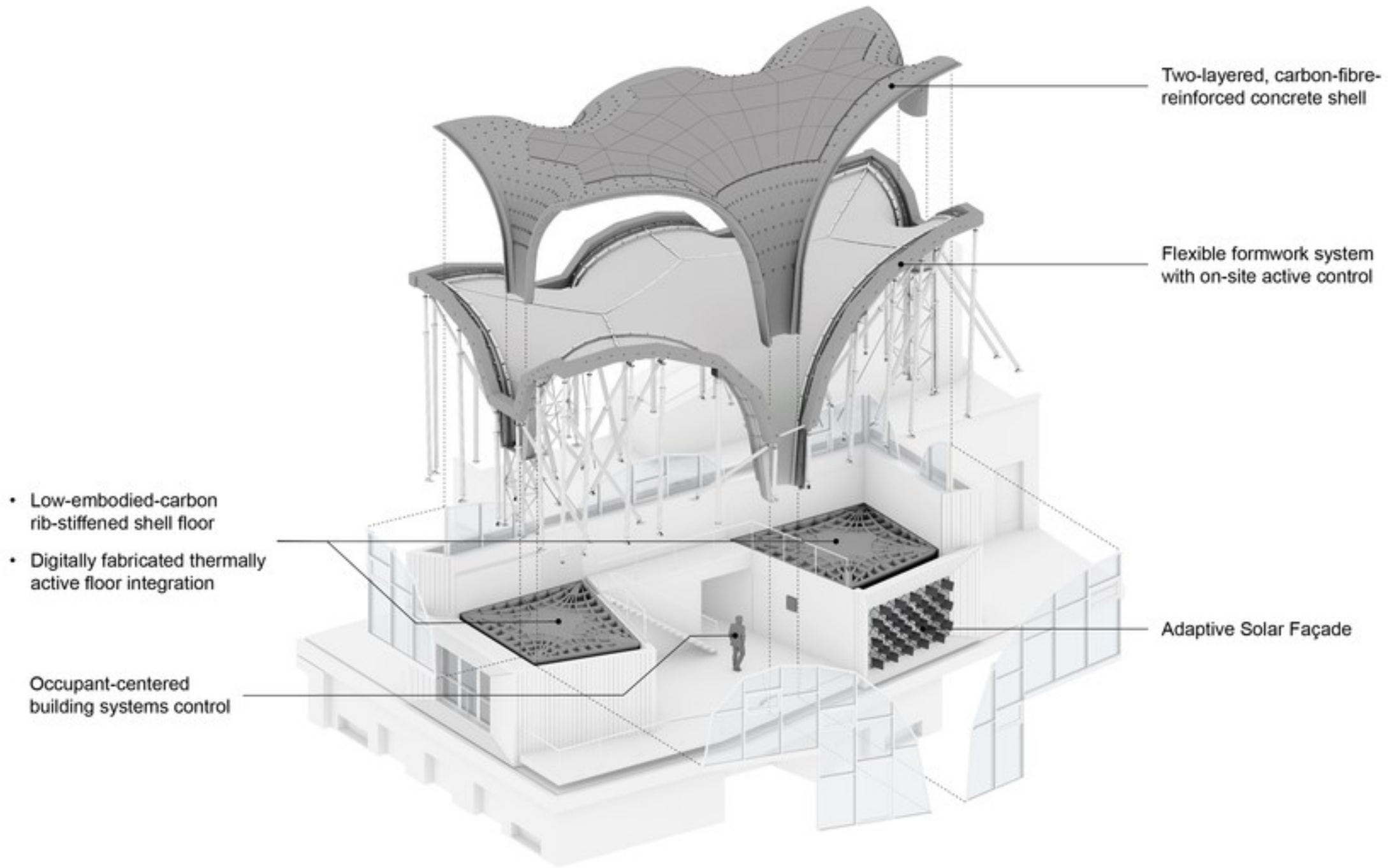












Two-layered, carbon-fibre-reinforced concrete shell

Flexible formwork system with on-site active control

Adaptive Solar Façade

- Low-embodied-carbon rib-stiffened shell floor
- Digitally fabricated thermally active floor integration

Occupant-centered building systems control